

Fire Alarm Control Panel NFS-640

Operations Manual

Document 51334
8/29/2002

Rev: **A1**

PN 51334:A1

ECN 02-406

Fire Alarm System Limitations

While a fire alarm system may lower insurance rates, it is not a substitute for fire insurance!

An automatic fire alarm system—typically made up of smoke detectors, heat detectors, manual pull stations, audible warning devices, and a fire alarm control with remote notification capability—can provide early warning of a developing fire. Such a system, however, does not assure protection against property damage or loss of life resulting from a fire.

The Manufacturer recommends that smoke and/or heat detectors be located throughout a protected premise following the recommendations of the current edition of the National Fire Protection Association Standard 72 (NFPA 72), manufacturer's recommendations, State and local codes, and the recommendations contained in the Guide for Proper Use of System Smoke Detectors, which is made available at no charge to all installing dealers. A study by the Federal Emergency Management Agency (an agency of the United States government) indicated that smoke detectors may not go off in as many as 35% of all fires. While fire alarm systems are designed to provide early warning against fire, they do not guarantee warning or protection against fire. A fire alarm system may not provide timely or adequate warning, or simply may not function, for a variety of reasons:

Smoke detectors may not sense fire where smoke cannot reach the detectors such as in chimneys, in or behind walls, on roofs, or on the other side of closed doors. Smoke detectors also may not sense a fire on another level or floor of a building. A second-floor detector, for example, may not sense a first-floor or basement fire.

Particles of combustion or "smoke" from a developing fire may not reach the sensing chambers of smoke detectors because:

- Barriers such as closed or partially closed doors, walls, or chimneys may inhibit particle or smoke flow.
- Smoke particles may become "cold," stratify, and not reach the ceiling or upper walls where detectors are located.
- Smoke particles may be blown away from detectors by air outlets.
- Smoke particles may be drawn into air returns before reaching the detector.

The amount of "smoke" present may be insufficient to alarm smoke detectors. Smoke detectors are designed to alarm at various levels of smoke density. If such density levels are not created by a developing fire at the location of detectors, the detectors will not go into alarm.

Smoke detectors, even when working properly, have sensing limitations. Detectors that have photoelectronic sensing chambers tend to detect smoldering fires better than flaming fires, which have little visible smoke. Detectors that have ionizing-type sensing chambers tend to detect fast-flaming fires better than smoldering fires. Because fires develop in different ways and are often unpredictable in their growth, neither type of detector is necessarily best and a given type of detector may not provide adequate warning of a fire.

Smoke detectors cannot be expected to provide adequate warning of fires caused by arson, children playing with matches (especially in bedrooms), smoking in bed, and violent explosions (caused by escaping gas, improper storage of flammable materials, etc.).

Heat detectors do not sense particles of combustion and alarm only when heat on their sensors increases at a predetermined rate or reaches a predetermined level. Rate-of-rise heat detectors may be subject to reduced sensitivity over time. For this reason, the rate-of-rise feature of each detector should be tested at least once per year by a qualified fire protection specialist. Heat detectors are designed to protect property, not life.

IMPORTANT! Smoke detectors must be installed in the same room as the control panel and in rooms used by the system for the connection of alarm transmission wiring, communications, signaling, and/or power. If detectors are not so located, a developing fire may damage the alarm system, crippling its ability to report a fire.

Audible warning devices such as bells may not alert people if these devices are located on the other side of closed or partly open doors or are located on another floor of a building. Any warning device may fail to alert people with a disability or those who have recently consumed drugs, alcohol or medication. Please note that:

- Strobes can, under certain circumstances, cause seizures in people with conditions such as epilepsy.
- Studies have shown that certain people, even when they hear a fire alarm signal, do not respond or comprehend the meaning of the signal. It is the property owner's responsibility to conduct fire drills and other training exercise to make people aware of fire alarm signals and instruct them on the proper reaction to alarm signals.
- In rare instances, the sounding of a warning device can cause temporary or permanent hearing loss.

A fire alarm system will not operate without any electrical power. If AC power fails, the system will operate from standby batteries only for a specified time and only if the batteries have been properly maintained and replaced regularly.

Equipment used in the system may not be technically compatible with the control. It is essential to use only equipment listed for service with your control panel.

Telephone lines needed to transmit alarm signals from a premise to a central monitoring station may be out of service or temporarily disabled. For added protection against telephone line failure, backup radio transmission systems are recommended.

The most common cause of fire alarm malfunction is inadequate maintenance. To keep the entire fire alarm system in excellent working order, ongoing maintenance is required per the manufacturer's recommendations, and UL and NFPA standards. At a minimum, the requirements of Chapter 7 of NFPA 72 shall be followed. Environments with large amounts of dust, dirt or high air velocity require more frequent maintenance. A maintenance agreement should be arranged through the local manufacturer's representative. Maintenance should be scheduled monthly or as required by National and/or local fire codes and should be performed by authorized professional fire alarm installers only. Adequate written records of all inspections should be kept.

Precau-L-4-2002.fm

Installation Precautions

Adherence to the following will aid in problem-free installation with long-term reliability:

WARNING - Several different sources of power can be connected to the fire alarm control panel. Disconnect all sources of power before servicing. Control unit and associated equipment may be damaged by removing and/or inserting cards, modules, or interconnecting cables while the unit is energized. Do not attempt to install, service, or operate this unit until this manual is read and understood.

CAUTION - System Reacceptance Test after Software Changes. To ensure proper system operation, this product must be tested in accordance with NFPA 72 Chapter 7 after any programming operation or change in site-specific software. Reacceptance testing is required after any change, addition or deletion of system components, or after any modification, repair or adjustment to system hardware or wiring.

All components, circuits, system operations, or software functions known to be affected by a change must be 100% tested. In addition, to ensure that other operations are not inadvertently affected, at least 10% of initiating devices that are not directly affected by the change, up to a maximum of 50 devices, must also be tested and proper system operation verified.

This system meets NFPA requirements for operation at 0-49° C/32-120° F and at a relative humidity of 85% RH - 93% per ULC - (non-condensing) at 30° C/86° F. However, the useful life of the system's standby batteries and the electronic components may be adversely affected by extreme temperature ranges and humidity. Therefore, it is recommended that this system and all peripherals be installed in an environment with a nominal room temperature of 15-27° C/60-80° F.

Verify that wire sizes are adequate for all initiating and indicating device loops. Most devices cannot tolerate more than a 10% I.R. drop from the specified device voltage.

Like all solid state electronic devices, this system may operate erratically or can be damaged when subjected to lightning-induced transients. Although no system is completely immune from lightning transients and interferences, proper grounding will reduce susceptibility. Overhead or outside aerial wiring is not recommended, due to an increased susceptibility to nearby lightning strikes. Consult with the Technical Services Department if any problems are anticipated or encountered.

Disconnect AC power and batteries prior to removing or inserting circuit boards. Failure to do so can damage circuits.

Remove all electronic assemblies prior to any drilling, filing, reaming, or punching of the enclosure. When possible, make all cable entries from the sides or rear. Before making modifications, verify that they will not interfere with battery, transformer, and printed circuit board location.

Do not tighten screw terminals more than 9 in-lbs. Over-tightening may damage threads, resulting in reduced terminal contact pressure and difficulty with screw terminal removal.

Though designed to last many years, system components can fail at any time. This system contains static-sensitive components. Always ground yourself with a proper wrist strap before handling any circuits so that static charges are removed from the body. Use static-suppressive packaging to protect electronic assemblies removed from the unit.

Follow the instructions in the installation, operating, and programming manuals. These instructions must be followed to avoid damage to the control panel and associated equipment. FACP operation and reliability depend upon proper installation by authorized personnel.

Precau-L-4-2002.fm

FCC Warning

WARNING: This equipment generates, uses, and can radiate radio frequency energy and if not installed and used in accordance with the instruction manual, may cause interference to radio communications. It has been tested and found to comply with the limits for class A computing device pursuant to Subpart B of Part 15 of FCC Rules, which is designed to provide reasonable protection against such interference when operated in a commercial environment. Operation of this equipment in a residential area is likely to cause interference, in which case the user will be required to correct the interference at his own expense.

Canadian Requirements

This digital apparatus does not exceed the Class A limits for radiation noise emissions from digital apparatus set out in the Radio Interference Regulations of the Canadian Department of Communications.

Le présent appareil numérique n'émet pas de bruits radioélectriques dépassant les limites applicables aux appareils numériques de la classe A prescrites dans le Règlement sur le brouillage radioélectrique édicté par le ministère des Communications du Canada.

Acclimate Plus™, HARSH™, NOTI-FIRE-NET™, ONYX™, and VeriFire™ are trademarks, and FlashScan® and VIEW® are registered trademarks of NOTIFIER. NION™ and UniNet™ are trademarks of NIS. NIS™ and Notifier Integrated Systems™ are trademarks and NOTIFIER® is a registered trademark of Fire-Lite Alarms, Inc. Echelon® is a registered trademark and LonWorks™ is a trademark of Echelon Corporation. ARCNET® is a registered trademark of Datapoint Corporation. Microsoft® and Windows® are registered trademarks of the Microsoft Corporation. LEXAN® is a registered trademark of GE Plastics, a subsidiary of General Electric Company.

This Page Intentionally Left Blank

Contents

About This Manual

Cautions and Warnings	9
Typographic Conventions	9
Supplemental Information	10
Shortcuts to Operating Functions	10

1. Introduction

Product Description	11
Operating Features	11

2. Use of the Controls

Introduction	13
System Status Indicator LEDs	14
Descriptions:	14
Control Keys	15
Acknowledge/Scroll Display	15
Signal Silence.....	15
Drill	15
System Reset	16
Lamp Test.....	16
Programming Keypad	17

3. Operation of the Control Panel

Overview	19
Normal Mode of Operation	20
Fire Alarm Mode of Operation	21
How the Control Panel Indicates a Fire Alarm	21
How to Respond to a Fire Alarm	21
Interpreting Fire Alarm Type Codes	22
System Trouble Mode of Operation	23
How the Control Panel Indicates a System Trouble	23
How to Respond to a System Trouble.....	23
Security Alarm Mode of Operation	25
How the Control Panel Indicates a Security Alarm	25
How to Respond to a Security Alarm	25
Interpreting Security Type Codes	26
Active Supervisory Signal Mode of Operation	27
How the Control Panel Indicates an Active Supervisory	27
How to Respond to an Active Supervisory	27
If a Latching Supervisory Type Code Displays.....	27
If Non-latching Type Code Displays	28
How to Interpret Supervisory Type Codes.....	28
Pre-Alarm Warning Mode of Operation	29
How the Control Panel Indicates a Pre-Alarm Warning	29
How to Respond to a Pre-Alarm Warning	29
Pre-Alarm Alert and Action Levels	29
Responding to a Pre-Alarm Warning.....	29
Interpreting Pre-Alarm Type Codes.....	29
Disabled Points Mode of Operation	30
Non-Alarm Mode of Operation	31
Purpose of Non-Alarm Points	31
How the Control Panel Indicates an Active Fire Control	31

How the Control Panel Indicates an Active Non-Fire Point	31
Active Trouble Monitor Mode of Operation	32
How the Control Panel Indicates an Active Trouble Monitor	32
How to Respond to an Active Trouble Monitor	32
Output Circuit Trouble Mode of Operation	33
Overview	33
How the Control Panel Indicates an NAC Trouble	34
How the Control Panel Indicates a Panel Circuit Trouble	34
How the Control Panel Indicates a Control/Relay Trouble	34
How to Respond to an NAC, Panel Circuit or Control/Relay Trouble	35
Operation of Special System Timers	36
What are System Timers?	36
How to View System Timer Selections	36
How System Timers Work	36
Auto Silence Timer	36
Alarm Verification Timer	36
Silence Inhibit Timer	37
Waterflow Circuit Operation	37
Style 6 and Style 7 Operation	37

4. Read Status Operation

Introduction	39
What is Read Status?	39
Quick Reference Key Sequences	39
Entering Read Status	39
Viewing and Printing a Read Status	40
How to View Read Status of Devices, Zones, and System Settings	41
Overview	41
How to Display the Total of Installed Devices	41
How to Display a Point or Zone for Read Status	41
How to View Read Status for a Detector	42
How to View Read Status for a Control/Relay or Monitor Module	43
How to View Read Status for a NAC or Panel Circuit	44
How to View Read Status for a Software Zone (Z01-Z99)	45
How to View Read Status for a Special Zone (F0-F9)	45
How to View Read Status for a Releasing Zone (R0-R9)	45
How to Read Status for System Functions	46
How to Read Status for Annunciator Selections	47
How to Read Status for Battery Levels	48
How to View Read Status for Event and Alarm History	49
Overview	49
How to View Read Status for Event History	49
How to View Read Status for Alarm History	50
How to Print Points, Event and Alarm History	51
Overview	51
How to Print Points	51
How to Print Event History	51
How to Print Alarm History	51
How to View and Print Hidden Event and Alarm History	52

Appendix A: Special Zone Operation

Overview	53
Releasing Zones (R0-R9)	54
Purpose of Releasing Zones	54
How to View Releasing Zone Selections	54
How Releasing Zones Operate	55

Time, Date, and Holiday Functions	57
Overview	57
How to View Time Control Selections	57
How to View Holiday Function Selections	58
How Time Control and Holiday Functions Work	58
NAC and Panel Circuit Coding	59
Overview of Coding	59
How to View Coding (F8) Selections	59
How to Respond to an Alarm with Coding	59
Presignal and Positive Alarm Sequence (PAS) Operation	60
Overview	60
What is Presignal and PAS?	60
How to View Presignal and PAS Selections	61
How to Respond to an Alarm with a Presignal Delay Timer (no PAS)	61
How to Respond to an Alarm with a Presignal Delay Timer (PAS selected)	62
Appendix B: Intelligent Detector Functions	
Descriptions for Intelligent Detector Functions	63
Appendix C: Remote Terminal Access	
General Description	65
Operating Modes	65
Local Terminal Mode (LocT)	66
Local Monitor Mode (LocM)	67
Remote Terminal Mode (RemT)	68
Using the CRT-2 for Read Status	69
Overview	69
Accessing Read Status Options	69
Read Point	70
Display Devices in Alarm or Trouble	70
Display the Status of all Programmed Points	71
View the History Buffer	71
Send the History Buffer to the CRT-2	71
View the Alarm History Buffer	71
Send the Alarm History Buffer to the CRT-2	72
Using the CRT-2 for Alter Status	73
Overview	73
Accessing Alter Status Options	73
Enable or Disable Detectors, Modules, or Panel Circuits	74
Change Alarm and Pre-Alarm levels	75
Clear the Verification Counter	75
Clear the Entire History Buffer	75
Set the Pre-Alarm for Alert or Action	76

Notes

About This Manual

Cautions and Warnings

This manual contains cautions and warnings to alert the reader as follows:



CAUTION: Information about procedures that could cause programming errors, runtime errors, or equipment damage.



WARNING: Indicates information about procedures that could cause irreversible damage to the control panel, irreversible loss of programming data or personal injury.

Typographic Conventions

This manual uses the following typographic conventions as listed in below:

When you see	Specifies	Example
text in small caps	the text as it appears in the LCD display or on the control panel	MARCH TIME is a selection that appears in the LCD display; or Press the ENTER key
text in quotes	a reference to a section or a LCD menu screen	“Read Status”; specifies the Read Status section or menu screen
bold text	In body text, a number or character that you enter	Press 1 ; means to press the number “1” on the keypad
italic text	a specific document	NFS-640 Installation Manual
a graphic of the key	In a graphic, a key as it appears on the control panel	Press  means to press the Escape key

Table 1 Typographic Conventions in this Manual

Supplemental Information

The table below provides a list of document sources (manuals) containing additional information regarding the NFS-640 and optional peripherals. The NOTIFIER document (DOC-NOT) chart provides the current document revision. A copy of this document is included in every NOTIFIER shipment.

For information on...	Refer to...	Part No.
Programming	NFS-640 Programming Manual	51333
Installation	NFS-640 Installation Manual	51332
SLC Wiring Instructions	SLC Wiring Manual	51253
Off-line programming utility	Veri•Fire Tools Help File Veri•Fire Medium Systems Help File	VeriFire-TCD VeriFire-CD
Compatible Devices	Device Compatibility Document	15378
Annunciators	Annunciator Control System	15842
	Annunciator Fixed Module	15048
	ACM-8R Annunciator Control Module	15342
	LCD-80 Manual	15037
	LCD-80TM Manual	51082
	LDM Series Lamp Driver Annunciator	15885
NCA Network Control Annunciator	51482	
Power Supply, Charger	ACPS-2406 Addressable Charger/Power Supply	51304
	APS-6R Auxiliary Power Supply Instruction Manual	50702
	CHG-120 Battery Charger Manual	50641
	FCPS-24 Field Charger/Power Supply	50059
Cabinets & Chassis	CAB-4 Series Installation PID	15330
Transponders & Transmitters	TM-4 PID (Reverse Polarity Transmitter)	51490
	UDACT Manual (Universal Digital Alarm Communicator/Transmitter)	50050
	XP Transponders	15888
	XP5 Series Manual	50786
Universal Zone Coder	UZY-256 Universal Zone Coder	15216
	UZY-256 Programming	15976
Voice Alarm Systems & Voice Evacuation	ACT-2	51118
	RM-1 Series Remote Microphone PID	51138
	XPIQ	51013
	VEC 25/50	50686
	Voice Alarm System Manual	51252
Networking	Noti•Fire•Net Manual, Network Version 4.0 and Higher	51584
	NCM-W/F PID	51533
	NCS Network Control Station	51658

Table 2 Supplemental Documentation

Shortcuts to Operating Functions



To the left of each program function, you'll find a keypad shortcut, which contains a series of keypad entries required to access the program function. All shortcuts start with the control panel in normal operation.

For example, the keypad shortcut to the left, shows how to enter the Read Status function with the control panel in normal operation, as well as how to exit the function.

1. Introduction

Product Description

The NFS-640 is a modular, intelligent Fire Alarm Control Panel (FACP) with an extensive list of powerful features suitable for most applications.

Operating Features

- Alarm Verification selection, to reduce unwanted alarms, for intelligent detector points
- Positive Alarm Sequence (PAS) and Presignal per NFPA 72
- Silence Inhibit timer and Auto Silence timer for Notification Appliance Circuits (NACs)
- March time/temporal code for Notification Appliance Circuits (NACs) and Panel Circuit modules
- Programmable Signal Silence, System Reset, and Alarm Activate functions through monitor modules
- Automatic time-of-day and day-of-week control functions, with holiday option
- AWACS (Advanced Warning Addressable Combustion Sensing) with nine field-adjustable Pre-Alarm levels with programmable Control-By-Event (CBE)
- Operate automatic smoke or heat detector sounder base on action Pre-Alarm level, with general evacuation on alarm level
- Security alarm point option with separate audible signal code.
- Centralized voice paging and audible alarm signaling options
- Programmable Control-By-Event control of outputs from individual alarm or supervisory addressable devices
- Networks with other FACP's and equipment for large applications.

Notes

2. Use of the Controls

Introduction

Listing of the controls and indicators and where to find information on their use:

Operating Components	Covered in
Eight System Status Indicator LEDs	"System Status Indicator LEDs" on page 14
Five Control Keys	"Control Keys" on page 15
Programming Keypad	"Programming Keypad" on page 17

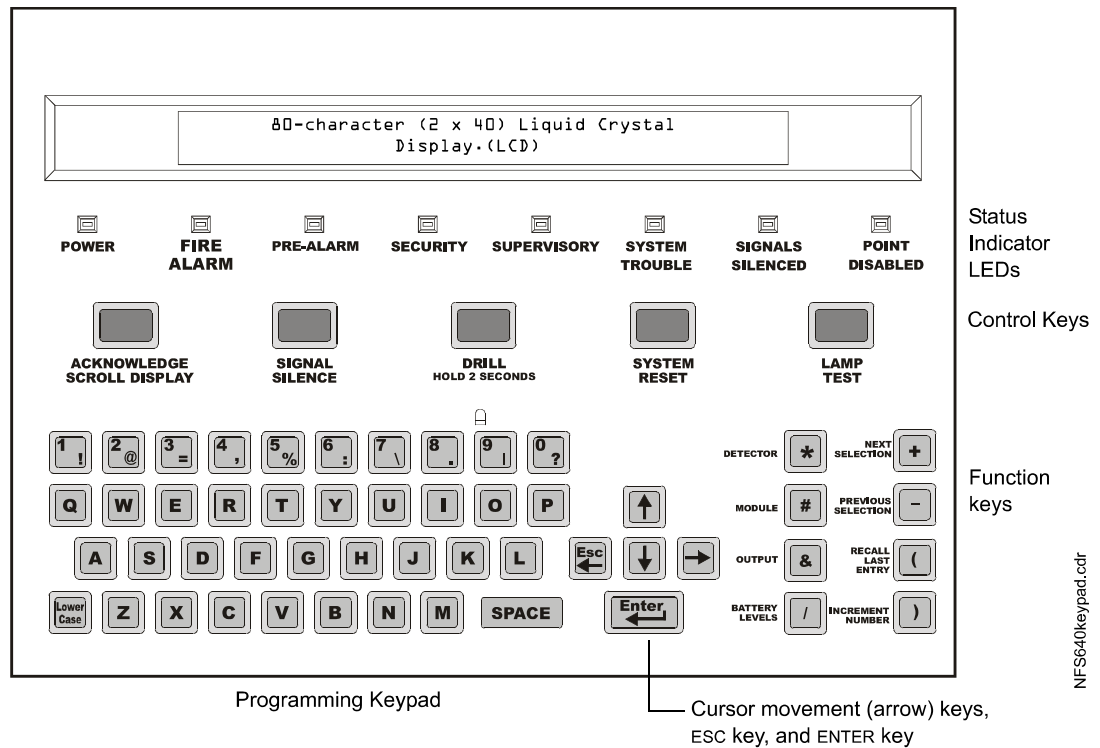

Figure 1 Control Panel Keys and Indicators

NFS640keypad.cdr

System Status Indicator LEDs

The control panel contains eight LEDs with labels as shown below:



Figure 2 System Status Indicator LEDs

Descriptions:

Indicator	Color	When Active	To Turn Off
POWER	Green	Lights when the proper primary AC power is applied. Remains lit while power is applied.	Always lit with AC power applied.
FIRE ALARM	Red	Flashes when a non-acknowledged fire alarm exists. Lights steadily after you acknowledge the fire alarm.	Clear the alarm condition and reset the system.
PRE-ALARM	Red	Flashes when a non-acknowledged fire Pre-Alarm exists. Lights steadily after you acknowledge the Pre-Alarm.	Clear the pre-alarm condition. (An Action Pre-Alarm requires a system reset.)
SECURITY	Blue	Flashes when a non-acknowledged Security alarm exists. Lights steadily after you acknowledge the alarm.	Clear the Security alarm condition and reset the system.
SUPERVISORY	Yellow	Flashes when a non-acknowledged Supervisory condition exists. Lights steadily after you acknowledge the event.	Clear the condition (Supervisory inputs require a system reset if they are latching. Refer to Table 6 page 28 for latching information.).
SYSTEM TROUBLE	Yellow	Flashes when a non-acknowledged system trouble exists. Lights steadily after you acknowledge the trouble.	Clear the trouble condition.
SIGNALS SILENCED	Yellow	Lights after a fire alarm condition occurs and after you press SIGNAL SILENCE.	Press SYSTEM RESET. DRILL will also turn off the LED.
POINT DISABLED	Yellow	Lights when one or more system devices are disabled.	Enable the device or remove the disabled device from the system program.

Table 3 Descriptions of System Status Indicator LEDs

Control Keys

The control panel provides five Control Keys as shown below:



Figure 3 Control Keys

Acknowledge/Scroll Display

Use the ACKNOWLEDGE/SCROLL DISPLAY key to respond to new alarm or trouble signals. When pressed, the control panel does the following:

- Silences the panel sounder
- Changes all active LED indicators from flashing to steady
- Sends an Acknowledge message to the History buffer and installed printers, CRT-2 terminals, and terminal mode LCD-80s
- Sends a signal to silence the sounders on the LCD-80 and ACS annunciators

You can also press this key to display multiple alarms or troubles. If more than one alarm or trouble exists, the control panel displays the next alarm or trouble for 3 seconds (or until you press the ACKNOWLEDGE/SCROLL DISPLAY key), then displays the next alarm or trouble.

Note: If Local Control is set to "NO", the FACP will not respond to ACKNOWLEDGE, and the piezo will not sound.

Signal Silence

Use the SIGNAL SILENCE key to silence the panel sounder and turn off all audio and visual devices connected to Notification Appliance Circuits. When pressed, the control panel does the following:

- Turns off the panel sounder
- Turns off all silenceable output circuits
- Lights the SIGNALS SILENCED LED
- Sends a SIGNALS SILENCED message to the History buffer and installed printers, CRT-2 terminals, and terminal mode LCD-80s

Note: If Local Control is set to "NO", the FACP will not respond to SIGNAL SILENCE.

Drill

Use the DRILL key to manually activate all silenceable outputs and Notification Appliance Circuits. To prevent accidental activation, you must press the DRILL key for 2 seconds. When pressed, the control panel does the following:

- Turns on all silenceable NACs
- Turns off the SIGNALS SILENCED LED
- Sends a Manual Evacuate message to the History buffer and installed printers, CRT-2 terminals, and terminal mode LCD-80s

Note: If Local Control is set to "NO", the FACP will not respond to DRILL.

System Reset

Use the SYSTEM RESET key to reset the control panel. When pressed, the control panel does the following:

- Clears ALL active inputs
- Interrupts resettable power
- Sends a “System Reset” message to the History buffer, and installed printers, CRT-2 terminals, and terminal mode LCD-80s
- Decouples from Noti•Fire•Net, if connected, for 60 seconds to allow CCBE to clear.

If any alarm or trouble exists after you press the SYSTEM RESET key, all NACs, control outputs, and panel audio and visual indicators will reactivate.

Note: Trouble conditions will not clear and re-report upon RESET.

Note: If Local Control is set to “NO”, the FACP will not respond to SYSTEM RESET.

Lamp Test

Use the LAMP TEST key to test the control panel LEDs, all installed panel circuits, and the panel sounder. When pressed and held, the control panel does the following:

- Lights all control panel LEDs
- Turns on the panel sounder
- Lights all segments of the LCD display. When the LAMP TEST key is held for longer than five seconds, the LCD will display the Software Revisions.
- Lights all panel circuit LEDs

Programming Keypad

The programming keypad includes:

- Function keys: DETECTOR, MODULE, OUTPUT, BATTERY LEVELS, NEXT SELECTION, PREVIOUS SELECTION, RECALL LAST ENTRY, AND INCREMENT NUMBER
- ENTER key
- Cursor movement keys: ESC/left arrow key, up key, right key, down key
- Alphabetic and numeric keys, with LOWER CASE selection key

Shown below is the Programming Keypad, with descriptions for the keys.

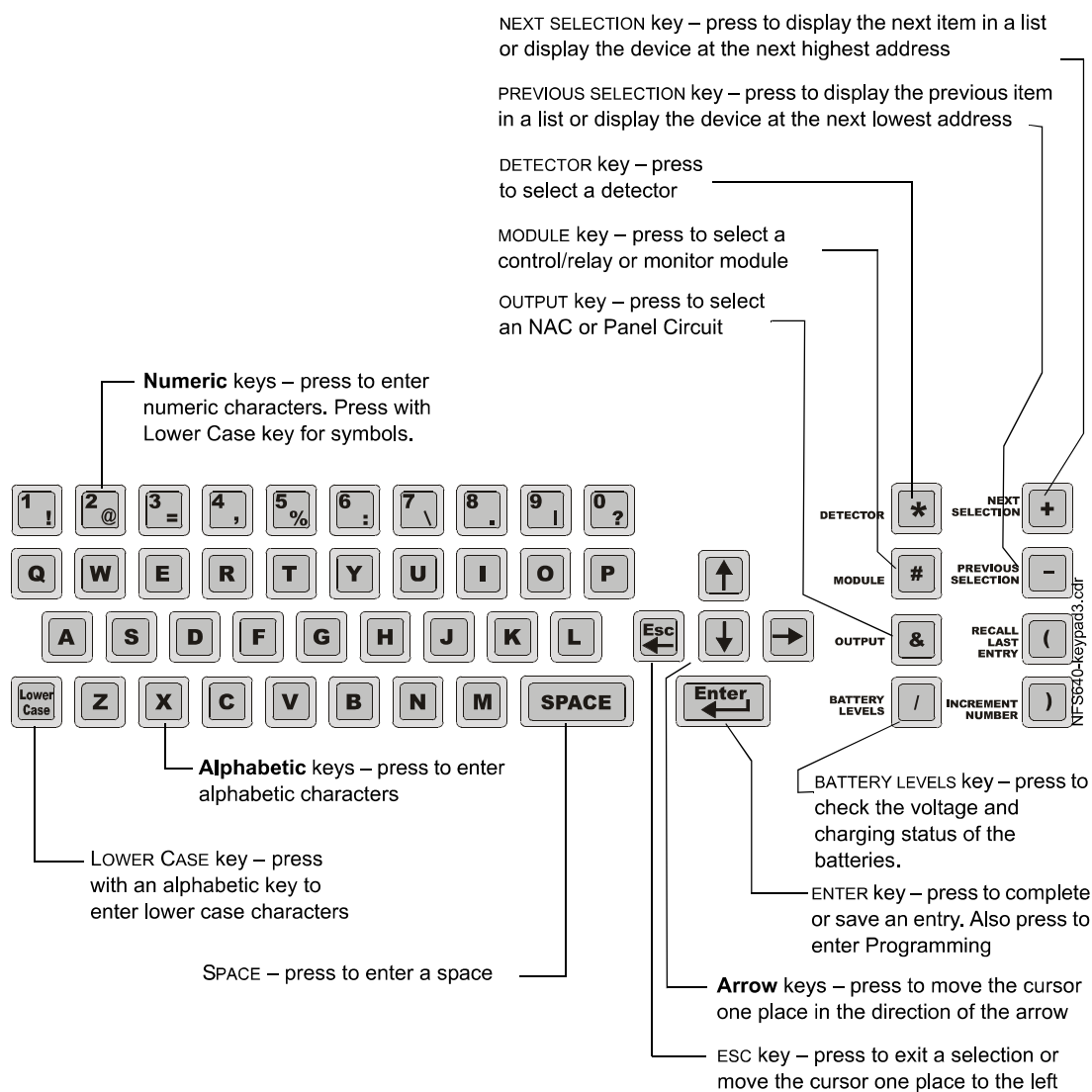

Figure 4 Programming Keypad

Notes

3. Operation of the Control Panel

Overview

This section contains instructions for operating the control panel. Listed below are the topics detailed in this section:

Section	Refer to Page
Normal Mode of Operation	20
Fire Alarm Mode of Operation	21
System Trouble Mode of Operation	23
Security Alarm Mode of Operation	25
Active Supervisory Signal Mode of Operation	27
Pre-Alarm Warning Mode of Operation	29
Disabled Points Mode of Operation	30
Non-Alarm Mode of Operation	31
Active Trouble Monitor Mode of Operation	32
Output Circuit Trouble Mode of Operation	33
Operation of Special System Timers	36
Waterflow Circuit Operation	37
Style 6 and Style 7 Operation	37

This manual also contains information on operating the control panel in the appendixes, listed as follows:

- Appendix A: Special Zone Operation on page 53
- Appendix B: Intelligent Detector Functions on page 63



WARNING: When used for CO₂ releasing applications, observe proper precautions as stated in NFPA 12. Do not enter the protected space unless physical lockout and other safety procedures are fully completed. Do not use software disable functions in the panel as lockout.

Normal Mode of Operation

The system operates in Normal mode when no alarms or troubles exist. In Normal mode, the control panel displays a System Normal message as follows

SYSTEM NORMAL	01:56P 071401 Sat
---------------	-------------------

Figure 5 Sample System Normal Message

In Normal mode, the control panel does the following functions at regular intervals:

- Polls all SLC devices, Panel Circuits, and the four NACs to check for valid replies, alarms, troubles, circuit integrity, and supervisory signals, and so forth
- Checks power supply troubles and batteries at 10-second intervals
- Sends a supervisory query on the optional terminal mode LCD-80 and verifies proper response
- Refreshes the LCD display and the optional terminal mode LCD-80 display and updates time
- Scans for any keypad or Control Key entries
- Performs a detector automatic test operation
- Tests system memory
- Monitors for microcontroller failure

Fire Alarm Mode of Operation

How the Control Panel Indicates a Fire Alarm

When an initiating device (detector or monitor module) activates, the control panel does the following:

- Produces a steady audible tone
- Activates the System Alarm relay (TB8)
- Flashes the FIRE ALARM LED
- Displays a Type Code that indicates the type of device that activated the fire alarm
- Displays ALARM in the status banner on the LCD display, along with information specific to the device, as shown below:

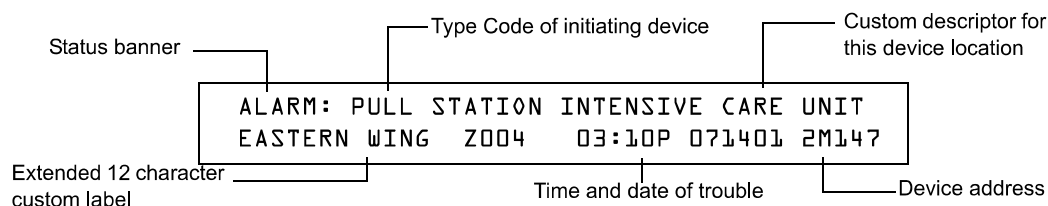

Figure 6 Sample Fire Alarm Display

- Sends an Alarm message to the LCD display, History buffer and installed printers, terminal mode LCD-80s, and CRT-2s.
- Latches the control panel in alarm. (You cannot return the control panel to normal operation until you correct the alarm condition and reset the control panel)
- Initiates any Control-By-Event actions
- Starts timers (such as Silence Inhibit, Auto Silence)
- Activates the general alarm zone (Z00)

How to Respond to a Fire Alarm

If the control panel indicates a fire alarm, you can do the following:

- To silence only the panel sounder:
Press the ACKNOWLEDGE/SCROLL DISPLAY key. The local sounder will silence and the FIRE ALARM LED will change from flashing to steady.
The control panel will send an acknowledge message to the LCD display, history buffer, and installed printers, terminal mode LCD-80s, and CRT-2s.
- To silence the panel sounder and any activated outputs that are programmed as silenceable:
Press the SIGNAL SILENCE key. The FIRE ALARM LED and SIGNALS SILENCED LED light steady. The control panel sends an Signal Silenced message to the History buffer and installed printers, terminal mode LCD-80s, and CRT-2s. The figure below shows a sample Alarm Silenced message.

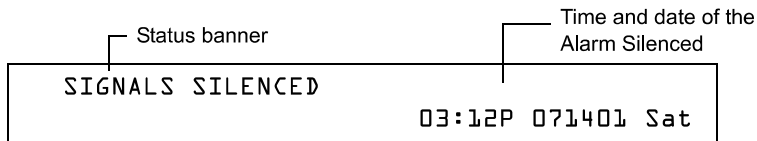

Figure 7 Sample Alarm Silenced Message

1. Check the Alarm message for the location and type of trouble.
2. Correct the condition causing the alarm.
3. When you finish correcting the alarm condition, press the SYSTEM RESET key to return the control panel to normal operation (indicated by the “System Normal” message). The control panel sends a “System Normal” message to the LCD display, History buffer and installed printers, terminal mode LCD-80s, and CRT-2s.

Interpreting Fire Alarm Type Codes

The Type Code that displays in the Alarm message indicates the function of the point that initiates the fire alarm. For example, a monitor module with a PULL STATION Type Code means that the monitor module connects to a manual pull station. The table below lists the Type Codes that can appear in an alarm message:

Monitor Modules			
Type Code	Latching (Y/N)	Purpose	What it does
Blank	Y	Indicates activation of a device with no description	Lights FIRE ALARM LED and activates CBE
HEAT DETECT	Y	Indicates activation of a conventional heat detector	Lights FIRE ALARM LED and activates CBE
MONITOR	Y	Indicates activation of an alarm-monitoring device	Lights FIRE ALARM LED and activates CBE
PULL STATION	Y	Indicates activation of a manual fire-alarm-activating device, such as a pull station.	Lights FIRE ALARM LED and activates CBE
RF MON MODUL	Y	Indicates activation of a wireless alarm-monitoring device	Lights FIRE ALARM LED and activates CBE
RF PULL STA	Y	Indicates activation of a wireless manual fire-alarm-activating device, such as a pull station	Lights FIRE ALARM LED and activates CBE
SMOKE CONVEN	Y	Indicates activation of a conventional smoke detector attached to an FZM-1	Lights FIRE ALARM LED and activates CBE
SMOKE DETECT	Y	Indicates activation of a conventional smoke detector attached to an FZM-1	Lights FIRE ALARM LED and activates CBE
WATERFLOW	Y	Indicates activation a waterflow alarm switch	Lights FIRE ALARM LED and activates CBE
EVACUATE SW	N	Emulates keypad Drill Switch	Activates all silenceable outputs
MAN. RELEASE	Y	Indicates activation of a monitor module programmed to a releasing zone to perform a releasing function.	Lights FIRE ALARM LED and activates CBE
MANREL DELAY	Y	Indicates activation of a monitor module programmed for a release output	Lights FIRE ALARM LED and activates CBE
SECOND SHOT	N	Provides second activation of releasing zone after soak timer has expired.	Indicates ACTIVE and activates CBE
Detectors			
Type Code	Latching (Y/N)	Purpose	What it does
SMOKE(ION)	Y	Indicates activation of an ion smoke detector	Lights FIRE ALARM LED and activates CBE
SMOKE(DUCT I)	Y	Indicates activation of a duct ion smoke detector	Lights FIRE ALARM LED and activates CBE
SMOKE(PHOTO)	Y	Indicates activation of a photo smoke detector	Lights FIRE ALARM LED and activates CBE
RF_SMOKE	Y	Indicates activation of a wireless photoelectric smoke detector	Lights FIRE ALARM LED and activates CBE
SMOKE(DUCTP)	Y	Indicates activation of a duct photo smoke detector	Lights FIRE ALARM LED and activates CBE
SMOKE(HARSH)*	Y	Indicates activation of a HARSH smoke detector	Lights FIRE ALARM LED and activates CBE
SMOKE(LASER)	Y	Indicates activation of a laser smoke detector	Lights FIRE ALARM LED and activates CBE
SMOKE(DUCTL)	Y	Indicates activation of a a duct laser smoke detector	Lights FIRE ALARM LED and activates CBE
AIR REF	Y	Indicates activation of a laser air reference detector.	Lights FIRE ALARM LED and activates CBE
HEAT(ANALOG)	Y	135°F intelligent thermal sensor	Lights FIRE ALARM LED and activates CBE
HEAT (ROR)	Y	15°F per minute rate-of-rise detector	Lights FIRE ALARM LED and activates CBE
SMOKE ACCLIM	Y	Indicates activation of detector (Acclimate Plus™), without freeze warning	Lights FIRE ALARM LED and activates CBE
SMOKE (ACCL+)	Y	Indicates activation of detector (Acclimate Plus™), with freeze warning	Lights FIRE ALARM LED and activates CBE
SMOKE MULTI*	Y	Multisensor smoke detector	Lights FIRE ALARM LED and activates CBE
*CLIP mode only			

Table 4 Fire Alarm Type Codes

System Trouble Mode of Operation

How the Control Panel Indicates a System Trouble

The system goes into system trouble when the control panel detects an electrical or mechanical fault. If no fire alarms exist, the control panel does the following:

- Produces a pulsed audible tone
- Activates the Trouble relay (TB9)
- Flashes the SYSTEM TROUBLE LED
- Displays a Type Code that indicates the type of device with a trouble.
- Displays TROUBL in the status banner on the LCD display as well as the type of trouble and information specific to the device, as shown in Figure 8 below.
- Sends a Trouble message to the LCD display, history buffer and installed printers, terminal mode LCD-80s, and CRT-2s.

Note: If a fire alarm exists when a trouble exists, the SYSTEM TROUBLE LED lights, but the Alarm message appears in the LCD display.

Typical Trouble message that appears on the LCD display:

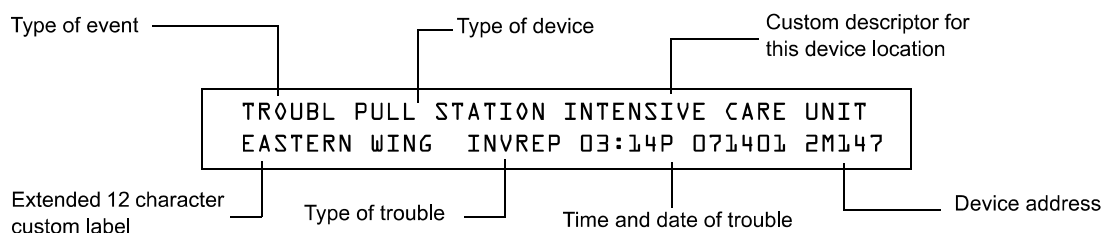

Figure 8 Sample Trouble Message

How to Respond to a System Trouble

If the control panel indicates a trouble, you can do the following:

4. Press the ACKNOWLEDGE/SCROLL DISPLAY key to silence the panel sounder and switch the SYSTEM TROUBLE LED from flashing to steady—regardless of the number of troubles, alarms, security and supervisory signals.

Note: Pressing the SIGNAL SILENCE key when only troubles exist, gives the same result as pressing the ACKNOWLEDGE/SCROLL DISPLAY key. The SIGNALS SILENCED LED does not light unless an alarm exists in the system.

5. The control panel sends an Acknowledge message to the History buffer and installed printers, terminal mode LCD-80s, and CRT-2s.

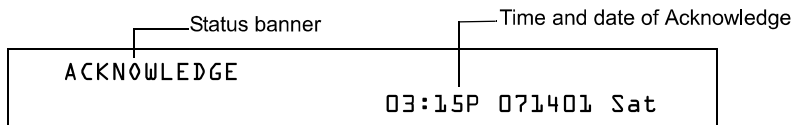

Figure 9 Sample Acknowledge Message

6. Check the trouble message for the location and type of trouble.

```

TROUBL MONITOR      MODULE ADDRESS M021 Z00 OPEN CIRCUIT 08:10A 082095 2M021
TROUBL MONITOR      MODULE ADDRESS M022 Z00 OPEN CIRCUIT 08:12A 082095 2M022
    
```

Figure 10 Sample Trouble Messages on CRT-2 or Printer

7. Correct the condition causing the trouble. If the trouble clears, the control panel sends a Clear Trouble message to the History buffer and installed printers, terminal mode LCD-80s, and CRT-2s.

Continued on the next page...

If all troubles clear and no supervisory signals or fire alarms exist, the control panel does the following:

- Returns to Normal operation (indicated by the “System Normal” message)
- Sends an “System Normal” message to the LCD display, History buffer and installed printers, terminal mode LCD-80, and CRT-2s
- Restores troubles automatically - even if troubles are not acknowledged

If multiple trouble conditions exist in the system, the LCD and optional terminal mode CRT-2 and LCD-80 displays automatically step through each trouble every 3 seconds in the following order:

1. Alarms, in order of address
2. Supervisory, in order of address
3. Troubles, in order of address

Press the ACKNOWLEDGE/SCROLL DISPLAY key and the display stops on the current trouble event for 1 minute, then begins to automatically step through remaining troubles. To manually step through remaining troubles, press the ACKNOWLEDGE/SCROLL DISPLAY key.

Security Alarm Mode of Operation (Not Suitable for Canadian Applications)

How the Control Panel Indicates a Security Alarm

The system goes into Security mode when a monitor module point programmed with a security Type Code activates. If no fire alarm exists, the control panel does the following:

- Produces a warbling audible tone
- Turns on the Security relay TB11
- Flashes the SECURITY LED (blue)
- Displays a Type Code that indicates the type of security alarm being generated
- Displays ACTIVE in the status banner on the control panel, along with information specific to the device
- Sends a Security message to the LCD display, History buffer, and installed printers, terminal mode LCD-80s, and CRT-2s
- Sends a Security message to the proprietary receiver via the network, if applicable.

Note: If a fire alarm exists, and there are silenced alarms (the SIGNALS SILENCED LED is lighted), a Security alarm will resound the panel sounder.

A Typical security message that appears on LCD display:

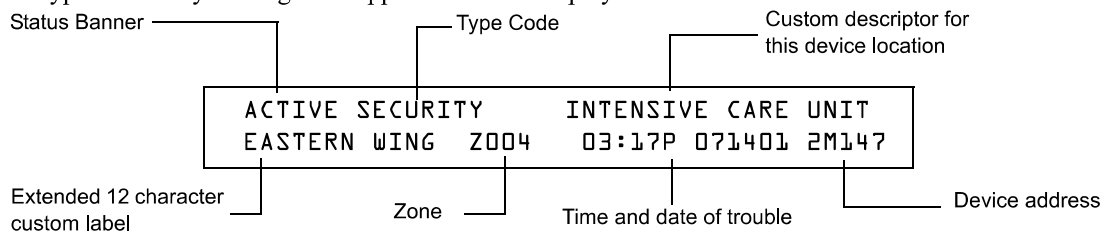

Figure 11 Sample Security Alarm Message

How to Respond to a Security Alarm

A Security Type Code latches the control panel. To return the control panel to normal operation, you must correct the condition causing the security condition, then reset the control panel. If the control panel indicates a security alarm, take the following action:

Note: If a fire alarm exists, and there are silenced alarms (the SIGNALS SILENCED LED is lighted), a Security alarm will resound the panel sounder.

1. Press the ACKNOWLEDGE/SCROLL DISPLAY key to silence the panel sounder and switch the SECURITY LED from flashing to steady—regardless of the number of troubles, alarms, supervisory, and security signals. The control panel sends a Security message to the History buffer and installed printers, terminal mode LCD-80s, and CRT-2s.
2. Correct the condition that activated the Security point.
3. When you finish correcting the Security condition, press the SYSTEM RESET key to return the control panel to normal operation (indicated by the “System Normal” message). The control panel sends a “System Normal” message to the LCD display, History buffer and installed printers, terminal mode LCD-80s, and CRT-2s.

Interpreting Security Type Codes

The Type Code that displays in the security alarm message indicates the type of security alarm being generated by the monitor module that initiates the alarm. For example, a monitor module with a Type Code of AREA MONITOR indicates an intruder in a protected premises area. The table below lists the Type Codes that can appear in a security alarm message.

<i>Monitor Modules</i>			
Type Code	Latching (Y/N)	Purpose	What it does
AREA MONITOR	Y	Monitors area surveillance equipment, such as motion detectors	Lights SECURITY LED, activates CBE
SECURITY	Y	Monitors security switches for tampering	Lights SECURITY LED, activates CBE
SYS MONITOR	Y	Monitors critical equipment for security	Lights SECURITY LED, activates CBE

Table 5 Security Type Codes

Active Supervisory Signal Mode of Operation

How the Control Panel Indicates an Active Supervisory

The system goes into Supervisory mode when a monitor module point programmed with a Supervisory type code activates. When a Supervisory point activates, the control panel does the following:

- Produces a warbling audible tone
- Turns on the Supervisory relay (TB10)
- Flashes the SUPERVISORY LED (yellow)
- Displays one of the Type Codes listed in Table 6.
- Displays ACTIVE in the status banner on the control panel, along with information specific to the device
- Sends a Supervisory message to the LCD display, History buffer, and installed printers, terminal mode LCD-80s, and CRT-2s

Note: If a fire alarm exists, and there are silenced alarms (the SIGNALS SILENCED LED is lighted), a Supervisory alarm will resound the panel sounder.

A Typical Supervisory message that appears on LCD display:

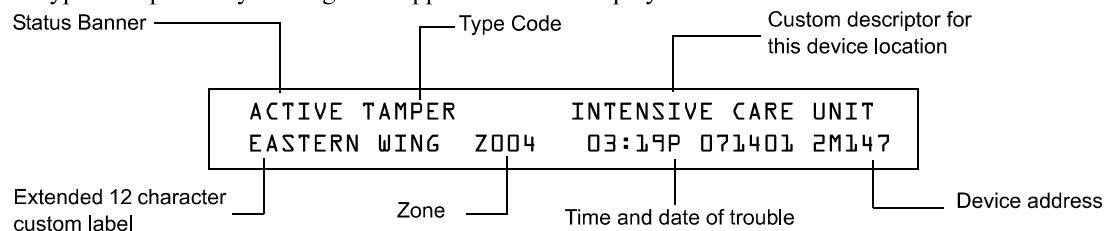

Figure 12 Sample Supervisory Signal Message

How to Respond to an Active Supervisory

If a Latching Supervisory Type Code Displays

Some Supervisory Type Codes latch the control panel (Refer to Table 6 for a list of these type codes). To return the control panel to normal operation, you must correct the condition causing the supervisory condition, then reset the control panel. Take the following action:

Note: If a fire alarm exists, and there are silenced alarms (the SIGNALS SILENCED LED is lighted), a Supervisory alarm will resound the panel sounder.

1. Press the ACKNOWLEDGE/SCROLL DISPLAY key to silence the panel sounder and switch the SUPERVISORY LED from flashing to steady—regardless of the number of troubles, alarms, and supervisory signals. The control panel sends a Supervisory message to the History buffer and installed printers, terminal mode LCD-80s, and CRT-2s.
2. Correct the condition that activated the supervisory point.
3. When you finish correcting the latching supervisory condition, press the SYSTEM RESET key to return the control panel to normal operation (indicated by the “System Normal” message). The control panel sends a “System Normal” message to the LCD display, History buffer and installed printers, terminal mode LCD-80s, and CRT-2s.

If Non-latching Type Code Displays

Some Supervisory Type Codes do not latch the control panel. (Refer to Table 6 for a list of these type codes). The control panel automatically returns to normal operation, when you correct the condition that activates the supervisory point. If the control panel indicates a non-latching supervisory point, take the following action:

Note: If a fire alarm exists, and there are silenced alarms (the SIGNALS SILENCED LED is lighted), a Supervisory alarm will resound the panel sounder.

1. Press the ACKNOWLEDGE/SCROLL DISPLAY key to silence the panel sounder and switch the SUPERVISORY LED from flashing to steady—regardless of the number of troubles, alarms, and supervisory signals. The control panel sends a Supervisory message to the History buffer and installed printers, terminal mode LCD-80s, and CRT-2s.
2. Correct the condition that activated the supervisory point.
3. The control panel automatically returns to normal operation (indicated by the “System Normal” message) and the control panel sends a “System Normal” message to the LCD display, History buffer and installed printers, terminal mode LCD-80s, and CRT-2s.

How to Interpret Supervisory Type Codes

The Type Code that displays in the Supervisory message indicates the function of the point that initiates the Supervisory. For example, a monitor module with a TAMPER Type Code means that the monitor module connects to a tamper switch.

Type Codes that can appear in an Supervisory message:

<i>Monitor Modules</i>			
Type Code	Latching (Y/N)	Purpose	What it does
WATERFLOW S	Y	Indicates supervisory condition for activated waterflow switch	Lights SUPERVISORY LED and activates CBE
RF SUPERVSRV	N	Monitors a radio frequency device	Lights SUPERVISORY LED and activates CBE
LATCH SUPERV	Y	Indicates latching supervisory condition	Lights SUPERVISORY LED and activates CBE
TRACK SUPERV	N	Indicates tracking supervisory condition	Lights SUPERVISORY LED and activates CBE
SPRINKLR SYS	Y	Indicates activation of sprinkler system	Lights SUPERVISORY LED and activates CBE
TAMPER	Y	Indicates activation of tamper switch	Lights SUPERVISORY LED and activates CBE
<i>Detectors</i>			
SUPERV(DUCTI)	N	Ion detector that indicates supervisory (non-alarm) condition	Lights SUPERVISORY LED and activates CBE
SUPERV(DUCTP)	N	Photo detector that indicates supervisory (non-alarm) condition	Lights SUPERVISORY LED and activates CBE
SUPERV(DUCTL)	N	Laser detector that indicates supervisory (non-alarm) condition	Lights SUPERVISORY LED and activates CBE

Table 6 Supervisory Type Codes

Pre-Alarm Warning Mode of Operation

How the Control Panel Indicates a Pre-Alarm Warning

The control panel activates a Pre-Alarm Warning if a detector exceeds the programmed Pre-Alarm Alert or Action level. When a detector activates a Pre-Alarm, the control panel does the following:

- Pulsed the panel sounder
- Flashes the PRE-ALARM LED
- Activates the Pre-Alarm zone (F9)
- Sends a Pre-Alarm message to the LCD display, History buffer and installed printers, terminal mode LCD-80s, and CRT-2s
- Displays a PREALARM status banner, the Type Code of the detector, and the Pre-Alarm level (Alert or Action) on the LCD display, along with information specific to the device as shown in Figure 13.

How to Respond to a Pre-Alarm Warning

Pre-Alarm Alert and Action Levels

The Pre-Alarm function is a programmable option which determines the system's response to real-time detector sensing values above the programmed setting. Use the Pre-Alarm function if you want to get an early warning of incipient or potential fire conditions. The Pre-Alarm function provides one of two levels of Pre-Alarm as follows:

Note: For detailed information on Pre-Alarm applications, refer to the *NFS-640 Programming Manual*.

- Alert – a non-latching condition that causes a Pre-Alarm when a detector reaches the programmed Pre-Alarm level.
- Action – a latching condition that causes a Pre-Alarm when a detector reaches the programmed Pre-Alarm level.

Responding to a Pre-Alarm Warning

The Pre-Alarm screen display is the same for both alert and action conditions. Following is a sample screen for a Pre-Alarm message.

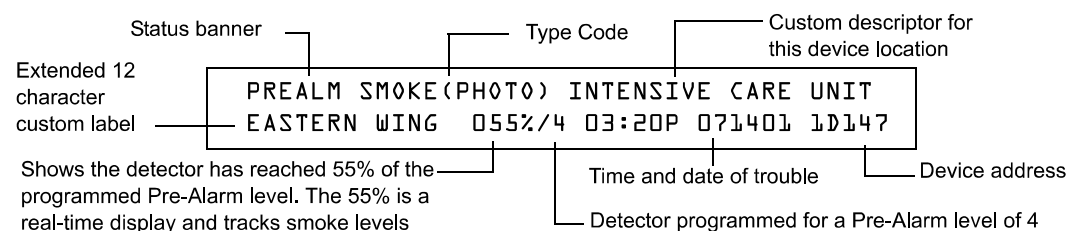

Figure 13 Sample of an Alert Pre-Alarm Message

An Alert Pre-Alarm automatically restores to normal when the detector sensitivity, programmable to one of nine settings, drops below the programmed Alert level. Zone F09 automatically clears when no Pre-Alarm conditions exist.

An Action Pre-Alarm latches until you reset the system - even if the detector sensitivity drops below the Action level. Zone F09 activates - but Zone Z00 (general alarm) and the trouble and alarm relays do not activate. The fifth zone programmed, not the first four, in the detector's CBE activates. A subsequent alarm condition for this detector clears the Action indication from the LCD display.

Interpreting Pre-Alarm Type Codes

The Type Code that displays in the Pre-Alarm warning indicates the function of the point that initiates the Pre-Alarm warning. Refer to the Detectors section of Table 4 for the Type Codes that can appear in a Pre-Alarm warning, and for descriptions of those Type Codes.

Disabled Points Mode of Operation

The control panel indicates disabled points by displaying a screen for each disabled detector, monitor module, control/relay module, and Panel Circuit. Disabled points do not cause an alarm or any Control-by-Event activity. If more than one point is disabled, the control panel automatically displays each point in the sequence in which the point was disabled.



CAUTION: Disabling a zone disables all input and output devices associated with the zone.

When one or more points are disabled, the control panel does the following:

- Holds all disabled output points in the off-state
- Flashes the SYSTEM TROUBLE LED
- Lights the POINT DISABLED LED
- Lights the TROUBLE LED for each Panel Circuit with a disabled point
- Sends a Disabled Point message to the LCD display, History buffer and installed printers, terminal mode LCD-80s, and CRT-2s
- Displays a message for each disabled point

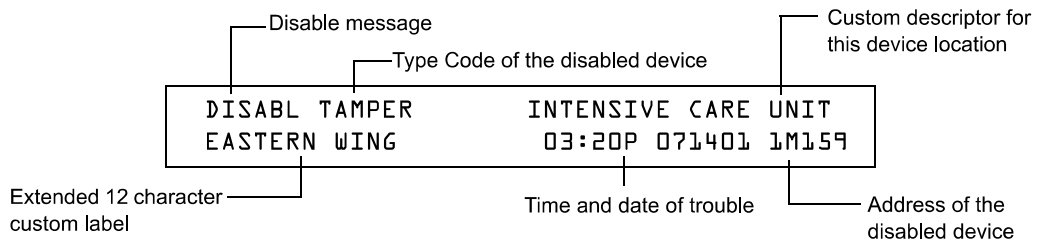

Figure 14 Sample Disabled Point Message

Non-Alarm Mode of Operation

Purpose of Non-Alarm Points

Non-Alarm points are addressable monitor modules programmed with one of the Non-Alarm Type Codes listed in Table 7. Non-Alarm points, except Non-Fire, operate like monitored system functions that can produce troubles—but with the differences shown in the following sections.

<i>Monitor Modules</i>			
Type Code	Latching (Y/N)	Purpose	What it does
ACCESS MONTR	N	Used for monitoring building access	Activates CBE
ACK SWITCH	N	Emulates panel Acknowledge switch	Silences panel sounder, gives an Acknowledge message on the panel LCD
ALLCALL PAGE	N	Activates all speaker circuits for paging.	Activates speakers and CBE
DRILL SWITCH	N	Emulates panel Drill switch	Activates silenceable outputs
FIRE CONTROL	N	Used for air handler shutdown, intended to override normal operating automatic functions	Activates CBE, does NOT light an indicator at the control panel
NON-FIRE	N	Used for energy management or other non-fire situations. Does not affect operation of the control panel	Activates CBE, does NOT light an indicator at the control panel
PAS INHIBIT	N	Inhibits Positive Alarm Sequence	Inhibits Positive Alarm Sequence
RESET SWITCH	N	Emulates keypad Reset switch	Resets control panel
SIL SWITCH	N	Emulates keypad Signal Silence switch	Turns off all activated silenceable outputs
TELE PAGE	N	Emulates Page Button on FFT-7	Allows remote paging to a fire area
ABORT SWITCH	N	Indicates Active at the panel	Aborts activation of a releasing zone

Table 7 Non-Alarm Type Codes

How the Control Panel Indicates an Active Fire Control

Activation of a FIRE CONTROL point causes the control panel to do the following:

- Initiates the monitor module Control-by-Event
- Send a message to the LCD display, History buffer and installed printers, terminal mode LCD-80s, and CRT-2s
- Display an ACTIVE status banner and FIRE CONTROL Type Code on the LCD display, along with information specific to the device

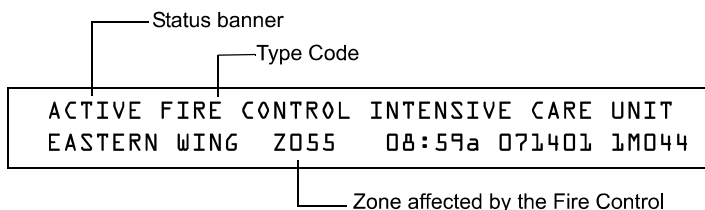

Figure 15 Sample Fire Control Point Display

How the Control Panel Indicates an Active Non-Fire Point

Non-Fire point operation does not affect control panel operation, nor does it display a message at the panel LCD. Activation of a Non-Fire point activates CBE—but does not cause any indication on the control panel. For example, you can program a Non-Fire point to turn lights in a zone to a lower setting when activated. In this case, when the point activates the control panel activates the point’s CBE to turn the lights down without any audio or visual indication on the control panel.

Active Trouble Monitor Mode of Operation

How the Control Panel Indicates an Active Trouble Monitor

Trouble Monitor Points are monitor modules programmed with the following Type Codes:

Type Code	Latching (Y/N)	Device Function	Point Function
AUDIO SYSTEM	N	Used for monitoring audio equipment audio amplifiers or associated equipment	Activates CBE
EQUIP MONITR	N	Used for recording access to monitored equipment	Activates CBE
POWER MONITR	N	Used to monitor remote power supplies or other external equipment	Activates CBE
TROUBLE MON	N	Used to monitor remote power supplies or other external equipment	Activates CBE

Table 8 Trouble Monitor Type Codes

These types of monitor modules operate like monitored system functions that can produce troubles—but with the following differences:

- The LCD display status banner displays ACTIVE as shown:

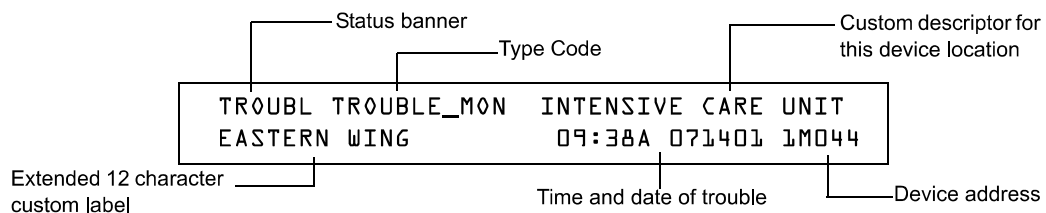

Figure 16 Sample Trouble Monitor Point Message

- The monitor module is non-latching: the module will return to normal when the trouble condition no longer exists.
- The monitor modules activate Control-by-Event
- The panel trouble relay transfers (TB-9)

How to Respond to an Active Trouble Monitor

If the control panel indicates an active Trouble Monitor Point, take the following action:

- Press the ACKNOWLEDGE/SCROLL DISPLAY key to silence the panel sounder and switch the SYSTEM TROUBLE LED from flashing to steady—regardless of the number of troubles, alarms, and supervisory signals.
- The control panel sends an Acknowledge message to the History buffer and installed printers, terminal mode LCD-80s, and CRT-2s. Check the trouble message for the location and type of trouble.
- Correct the condition causing the trouble.
- When the trouble condition is corrected, the panel will return to normal operation (indicated by the “System Normal” message).
- The control panel sends a “System Normal” message to the LCD display, History buffer and installed printers, terminal mode LCD-80s, and CRT-2s.

Output Circuit Trouble Mode of Operation

Overview

Output circuits include NACs, Panel Circuits 1-64, Control/Relay Modules, and Transponder Points. This section contains a description of control panel operation for each type of output circuit.

- Four NACs are included on the control panel
- Panel Circuits include ICM-4RK, CRM-4RK, VCM-4RK or DCM-4RK panel modules via connection to the control panel
- Control/Relay Modules connected to the control panel on an SLC
- Transponder Points include XPC (CLIP only) or XP5-C (CLIP or FlashScan).

<i>Trouble Type Codes for Control Modules and Panel/NAC Circuits</i>			
Type Code	Silenceable (Y/N)	Configuration	Device Function
CONTROL	N	Panel Circuit relay or NAC	Supervised NAC
RELAY	N	FORM-C relay	Relay Output
BELL CIRCUIT	N	Panel Circuit relay or NAC	Supervised NAC for notification appliance
STROBE CKT	N	Panel Circuit relay or NAC	Supervised NAC for notification appliance
HORN CIRCUIT	N	Panel Circuit relay or NAC	Supervised NAC for notification appliance
AUDIBLE CKT	N	Panel Circuit relay or NAC	Supervised NAC for notification appliance
SPEAKER	N	Panel Circuit relay or NAC	Supervised NAC for speaker circuit
REL END BELL	N	Panel Circuit relay or NAC	Supervised NAC for notification appliance
blank	N	Panel Circuit relay or NAC	Supervised NAC for undefined device
RELEASE CKT	N	NAC	Releasing Circuit, nonpower-limited, supervised for opens, shorts and ground faults (always non-silenceable)
REL CKT ULC	N	NAC	Releasing Circuit, power-limited, supervised for opens and ground faults
REL AUDIBLE	N	Panel Circuit Relay or NAC	NAC, activated upon release
NONRESET CTL*	N	Form-C Relay and NAC	Relay output, unaffected by "System Reset" command
TELEPHONE	N	Panel Circuit relay or NAC	Standard Telephone circuit
REL CODE BELL**	N	NAC only	Supervised NAC (NFS-640 NAC only)
INSTANT RELE	N	NAC	NAC, short = normal; supervised for open circuits and ground faults. Always non-silenceable and switch-inhibited.
ALARMS PEND	N	Panel Circuit or NAC	Output that will activate upon receipt of an alarm condition, and remain in the alarm state until all alarms have been acknowledged.
CONTROL NAC**	N	Panel Circuit relay or NAC	Supervised NAC
GEN ALARM	Y		Control Module, an XPC-8 circuit, or an XP5-C (in NAC mode) configured as a Municipal Box Transmitter for NFPA 72 Auxiliary Fire Alarm Systems application (MBT required). This Type ID can also be used for general alarm activation.
GEN SUPERVIS	Y		Control Module, an XPR-8 relay, or an XP5-C (in relay mode) activated under any Supervisory condition (includes sprinkler type).
GEN TROUBLE	Y		Control Module, an XPR-8 relay, or an XP5-C (in relay mode) activated under any System Trouble condition.
GENERAL PEND	Y		Control Module, an XPC-8 circuit, or an XP5-C (in NAC mode) that will activate upon receipt of an alarm and/or trouble condition, and remain in the ON state until all events have been ACKNOWLEDGED.
TROUBLE PEND	N		Control Module, an XPC-8 circuit, or an XP5-C (in NAC mode) that will activate upon receipt of a trouble condition, and remain in the ON state until all troubles have been ACKNOWLEDGED.
* Type Code is Control Module type code only.			
** Type Code is Panel/NAC Circuit type code only.			

Table 9 Control Module and Panel/NAC Circuit Trouble Type Codes

How the Control Panel Indicates an NAC Trouble

A Trouble occurring on an NAC causes the control panel to do the following:

- Produce a pulsed audible tone
- Flash the SYSTEM TROUBLE LED
- Turn on the Trouble relay (TB9)
- Send a message to the LCD display, History buffer and installed printers, terminal mode LCD-80s, and CRT-2s
- Display a TROUBL status banner and a CONTROL Type Code on the LCD display, along with information specific to the device

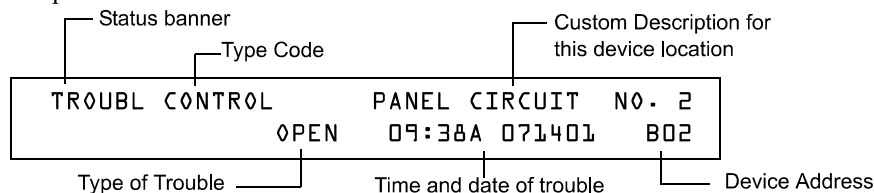

Figure 17 Sample of an NAC in Trouble Message

How the Control Panel Indicates a Panel Circuit Trouble

A trouble occurring on a Panel Circuit causes the control panel to do the following:

- Produce a pulsed audible tone
- Flash the SYSTEM TROUBLE LED
- Turn on the Trouble relay (TB9)
- Send a message to the LCD display, History buffer and installed printers, terminal mode LCD-80s, and CRT-2s
- Display a TROUBL status banner and CONTROL Type Code on the LCD display, along with information specific to the device

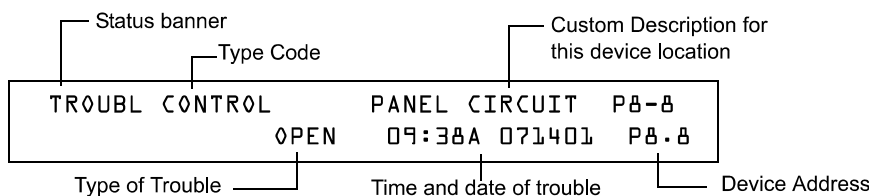

Figure 18 Sample of a Panel Circuit in Trouble Message

How the Control Panel Indicates a Control/Relay Trouble

A trouble occurring on a control/relay module or control/relay transponder causes the control panel to do the following:

- Produce a pulsed audible tone
- Flash the SYSTEM TROUBLE LED
- Turn on the Trouble relay (TB9)
- Send a message to the LCD display, History buffer and installed printers, terminal mode LCD-80s, and CRT-2s
- Display a TROUBL status banner and CONTROL Type Code on the LCD display, along with information specific to the device

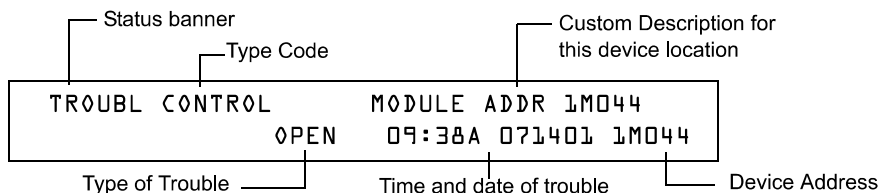

Figure 19 Sample of a Control/Relay Module in Trouble Message

How to Respond to an NAC, Panel Circuit or Control/Relay Trouble

If the control panel indicates an active NAC, Panel Circuit or Control/Relay Trouble, take the following action:

1. Press the ACKNOWLEDGE/SCROLL DISPLAY key to silence the panel sounder and switch the SYSTEM TROUBLE LED from flashing to steady—regardless of the number of troubles, alarms, and supervisory signals.
2. The control panel sends an Acknowledge message to the History buffer and installed printers, terminal mode LCD-80s, and CRT-2s. Check the trouble message for the location and type of trouble.
3. Correct the condition causing the trouble.
4. When the trouble condition is corrected, the panel will return to normal operation (indicated by the “System Normal” message).
5. The control panel sends a “System Normal” message to the LCD display, History buffer and installed printers, terminal mode LCD-80s, and CRT-2s.

Operation of Special System Timers

What are System Timers?

There are user-programmable time delays for three specific functions: the Auto Silence Timer, the Alarm Verification Timer, and the Silence Inhibit Timer. Figure 20 shows a sample System Function Selection screen with system timer settings. For instructions on changing system functions, refer to the *NFS-640 Programming Manual*.

How to View System Timer Selections

You can use the Read Status Entry option (explained in Chapter 4) to view the current selection for the System Timers. To do so, press the keys shown below in sequence:



The LCD display shows the current selections for System Functions, which includes the three system timers.

Sample LCD display of a System Function screen with system timer selections:

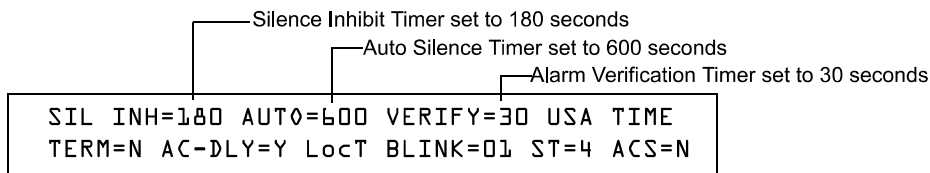

Figure 20 Sample System Function Selection Screen

How System Timers Work

The control panel can operate with special system timers: Auto Silence Timer, Alarm Verification Timer and Silence Inhibit Timer.

Auto Silence Timer

A timer that functions like pressing the SIGNAL SILENCE key. When the Auto Silence Timer reaches its programmed value (600-900 seconds), the control panel automatically shuts off all active outputs programmed as silenceable. To restart the Auto Silence Timer, press the DRILL key.

Alarm Verification Timer

A timer that directs the control panel to ignore a fire alarm for a smoke detector, programmed for Alarm Verification, while the Alarm Verification Timer is counting. Table 10 contains a summary of how the Alarm Verification Timer works.

If	The control panel does this
A second fire alarm occurs while the Alarm Verification Timer is counting	Ignores the Alarm Verification Timer
The Alarm Verification Timer elapses and a fire alarm still exists	Activates the fire alarm
The Alarm Verification Timer expires and a fire alarm no longer exists	Increments the Alarm Verification counter (up to 99) for the device and returns to normal operation

Table 10 Alarm Verification Timer Operation

Continued on the next page...

Silence Inhibit Timer

A timer that disables the SIGNAL SILENCE key function for the programmed time (0-300 seconds) when a fire alarm occurs. A Silence Inhibit Timer starts at the first fire alarm and restarts with each new fire alarm.

Waterflow Circuit Operation

If a monitor module programmed with a WATERFLOW Type Code initiates a fire alarm, the control panel disables the SIGNAL SILENCE key and the Auto Silence Timer. Refer to the *NFS-640 Installation Manual* for information on Waterflow circuits.

Style 6 and Style 7 Operation

Style 6 and Style 7 are supervised methods of communicating with addressable devices. If the control panel detects a trouble (open or short), it will drive both ends of the loop, maintaining communication in an unsupervised method. The latching trouble will display on the panel as a Style 6 trouble until you correct the condition and press reset. Style 7 configuration of the SLC requires the use of ISO-X modules.

Notes

4. Read Status Operation

Introduction

This section contains instructions and sample screens to show how to access all Read Status functions and menus.

For information on Read Status using a CRT-2 refer to Appendix C: Remote Terminal Access .

What is Read Status?

Read Status is a control panel function that lets you view system program information—but not change any programmed settings. The Read Status function lets you do the following:

- View Read Status information without entering a password.
- Enter and operate Read Status functions while the control panel provides full fire protection.
- View Read Status information while a fire alarm or trouble condition exists.

Note: If a fire alarm or trouble occurs while you are in Read Status, the control panel automatically exits Read Status operation and displays the new fire alarm or trouble.

Quick Reference Key Sequences



For quick reference, in the left margin next to each Read Status option is a block that shows the key sequence needed to view that option.



For example, the block to the left shows how to display the “Read Point” screen:



Entering Read Status

To enter Read Status, follow these steps:

6. From the “System Normal” screen, press the ENTER key. The control panel displays the “Entry” screen as shown below;

```

┆=PROGRAMMING      2=READ STATUS ENTRY
(ESCAPE TO ABORT)
  
```

7. From the “Entry” screen, press the 2 key. The control panel displays the “Read Status Options” screen as shown below:

```

READ POINT=0 HIST=2 ALARM HIST=4 <ENTER>
PRNT POINT=1 HIST=3 ALARM HIST=5 <ENTER>
  
```

Viewing and Printing a Read Status

To view or print Read Status information follow the instructions below:

Option	Press	Lets you
Read Point	0 key, ENTER key	View information for a detector, module, NAC, Panel Circuit, or zone
Print Points	1 key, ENTER key	Print information for all installed points in the system
Read History	2 key, ENTER key	Display the total number of events in the History buffer and step through each event in sequence
Print History	3 key, ENTER key	Print the contents of the History buffer (up to 800 events)
Read Alarm History	4 key, ENTER key	View a display of the number of alarms in the Alarm History buffer, then scroll through each alarm event
Print Alarm History	5 key, ENTER key	Print the contents of the Alarm History buffer (up to 200 events)

Note: If attempting to read a point that is not installed, the control panel displays “Not Installed”.

During all Read Status operations (except print operations) the control panel starts a 2-minute timer each time you press a key. If the control panel does not detect a key press for 2 minutes, the control panel exits Read Status and returns to the “System Normal” display.

In Read Status, you can also do the following:

- Press the ESC key to delete the previous entry.
- Press the SYSTEM RESET key to abort Read Status.

How to View Read Status of Devices, Zones, and System Settings

Overview

Read Point options 0, 2, and 4 in the Read Status Screen let you display and view information for devices and zones programmed into the control panel, as well as view system and annunciator settings. This section provides instructions and sample displays so you can view Read Status.

Topics covered in this section:

To view Read Status for	Refer to
Intelligent Detectors	"How to View Read Status for a Detector" on page 42
Control/relay and Monitor modules	"How to View Read Status for a Control/Relay or Monitor Module" on page 43
NAC and Panel Circuits	"How to View Read Status for a NAC or Panel Circuit" on page 44
Software Zones (Z01-Z99)	"How to View Read Status for a Software Zone (Z01-Z99)" on page 45
Special Zones (F0-F9)	"How to View Read Status for a Special Zone (F0-F9)" on page 45
Releasing Zones (R0-R9)	"How to View Read Status for a Releasing Zone (R0-R9)" on page 45
System Functions	"How to Read Status for System Functions" on page 46
Annunciator Selections	"How to Read Status for Annunciator Selections" on page 47

How to Display the Total of Installed Devices

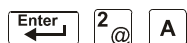

To view the total number of installed devices, enter the "Read Status" screen by pressing the ENTER key, then 2, then A. A screen similar to the following will appear:

```
L1:159Dets, 159Mods  L2:055Dets, 047Mods
Panel Outputs: 64  Bells: 04
```

How to Display a Point or Zone for Read Status



From the "Read Status" screen, press 0, then press the ENTER key to display the "Read Point Entry" screen as shown below:

```
ZONE=Z1AA1E      DETECTOR=*1LDAAA1E
MODULE=#1LMAA1E  OUTPUT CKT=B1AA1E
```

- To view a detector, press DETECTOR *****, SLC number, detector SLC address, ENTER.
- To view a zone, press **Z**, zone number, ENTER.
- To view a monitor or control/relay module, press MODULE **#**, SLC number, module SLC address, ENTER.
- To view a Panel Circuit or an NAC, press OUTPUT **&**, two-digit address, (for example 01 for B01, 11 for Panel Circuit 1.1, etc.), ENTER.

When you select a device or a zone, the control panel displays information for the device or zone, but does not send this information to the serial ports or the History buffer.

How to View Read Status for a Detector

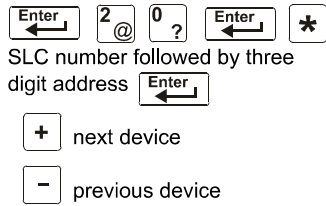

From the “Read Status” screen, press **0**, then press the ENTER key. You can now view Read Status for a detector as follows: press DETECTOR, enter the SLC number followed by the three digit address, then press the ENTER key. For example, to read the status of detector 1D002: press DETECTOR, enter the SLC number (1), enter address 002, then press the ENTER key. The control panel now displays information about the detector, as shown below.

The display and descriptions of the fields are shown below:

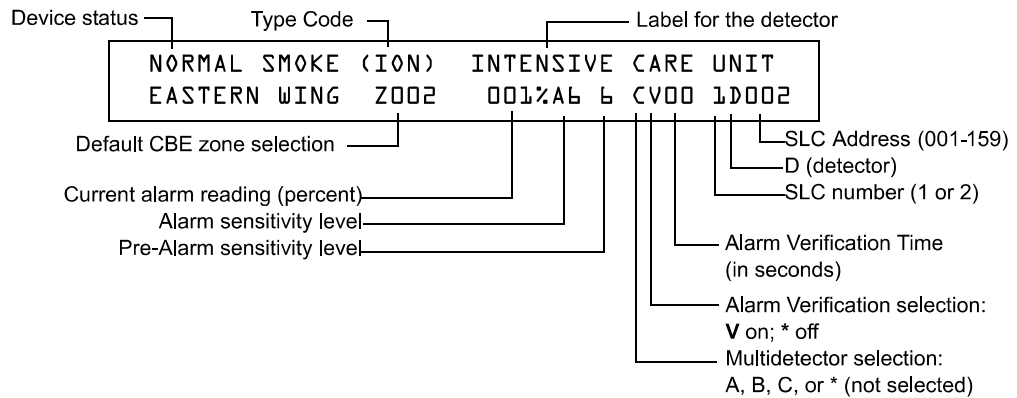

Figure 21 Sample Detector Read Status Display

- **Device Status** The status of the detector: Normal, Alarm, or Test.
- **Type Code** The software Type Code that identifies the type of detector. (Refer to “Point Programming” in NFS-640 Programming Manual.)
- **Default CBE Zone Selection** This is the first zone in the 5 zone CBE list. Defaults are Zone 001 (Heat detectors) Zone 002 (Ion detectors) Zone 003 (Photo detectors) Zone 004 (Laser detectors) Zone 005 (Multisensor). Values may differ depending on point programming.
- **Current alarm reading (xxx%)** The current alarm reading of the detector, as a percentage of the alarm sensitivity setting.
- **Alarm sensitivity level (Ax)** The alarm sensitivity (x=1-9) entered in the Detector Sensitivity Screen.
- **Pre-Alarm sensitivity level** The Pre-Alarm Sensitivity (1-9; 0 = Pre-Alarm not used) entered in the Detector Settings Screen.

Note: Refer to “Detector Sensitivity Settings” in the *NFS-640 Programming Manual* for more information on the Pre-Alarm and Alarm Sensitivity settings

- **Cooperative Multi-Detector selection** A smoke detector programmed to evaluate readings from nearby detectors in making Alarm or Pre-Alarm decisions. Cooperative Multi-Detector sensing also allows the combination of ionization with photoelectric technology in reaching an alarm decision.
* – Multi-not used.
A – combines the detector’s alarm decision with the next SLC address above.
B – combines the detector’s alarm decision with the next SLC address below.
C – combines the detector’s alarm decision with the next SLC address above and the next SLC address below.
- **Alarm Verification (* or V)**
* – Alarm Verification not programmed for this detector.
V – Alarm Verification enabled.
Alarm Verification is a user-defined global time function that can reduce the number of nuisance alarms. Refer to page 36 for more information.
- **Device SLC Address** The SLC address of the detector.

How to View Read Status for a Control/Relay or Monitor Module

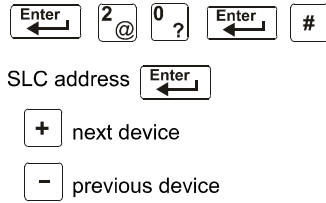

From the “Read Status” screen, press 0, then press the ENTER key. You can now view Read Status for a monitor or a control/relay module as follows: press MODULE, enter the SLC address, then press the ENTER key. For example, to read the status of a FCM-1 module 2M147: press MODULE, enter 2 then 147, then press the ENTER key. The control panel now displays information about the module as shown in Figure 22.

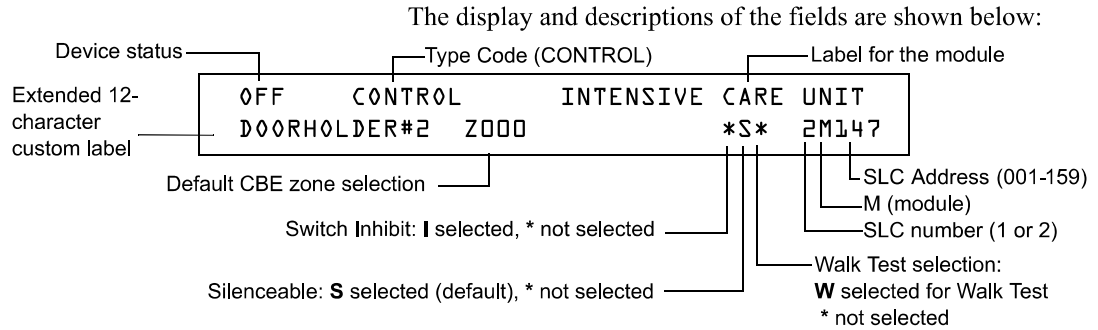
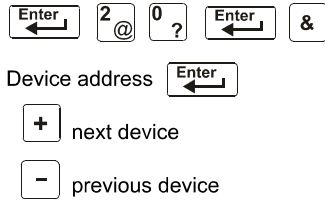

Figure 22 Sample Control/Relay or Monitor Module Read Status Display

- **Device Status** The status of the module: control/relay module [On (device active) OFF (device not active)] or monitor module (Normal, Alarm, or Test).
- **Type Code** The software Type Code that identifies the type of module. (Refer to “Point Programming” in the *NFS-640 Programming Manual*.)
- **CBE list** Only the first zone in the device’s CBE list will be displayed.
- **Device SLC Address** The SLC address of the module.
- **Switch Inhibit (control/relay module only)** Displays whether the remote ON/OFF capability of the device is inhibited. (I=on; *=off).
- **Silenceable (control/relay module only)** A selection that specifies if the device can be silenced during an alarm by pressing the SIGNAL SILENCE key.
- **Walk Test (control/relay module only)** A selection that specifies if the device will activate during a Walk Test.

How to View Read Status for a NAC or Panel Circuit



From the “Read Status” screen, press **0**, then press the ENTER key. You can now view Read Status for a NAC or Panel Circuit as follows: press OUTPUT, enter the device address, then press the ENTER key. For example, to read the status of NAC 0-2: press OUTPUT, enter 02, then press the ENTER key. The control panel now displays information for an NAC as shown in Figure 23.

The display and descriptions of the fields are shown below:

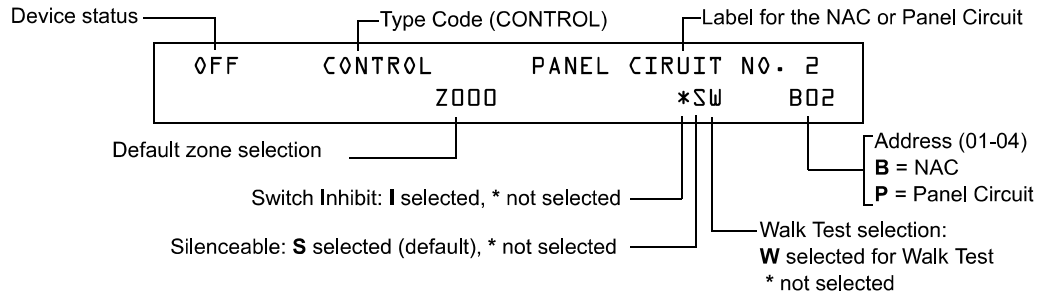
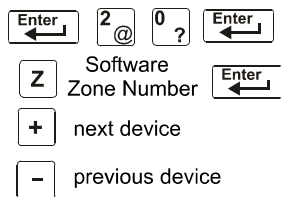

Figure 23 Sample NAC & Panel Circuit Read Status Display

- **Device Status** The status of the device: ON (device active) OFF (device not active).
- **Type Code** The software Type Code that identifies the type of NAC or Panel Circuit. Refer to “Appendix F - Type Codes” in *NFS-640 Programming Manual*.
- **CBE List** Only the first zone in the NAC or Panel circuit’s CBE list will be displayed here.
- **Device Address** The address of the NAC (01-04) or Panel Circuit (1-1 - 8-8)
- **Switch Inhibit** A selection for disabling the switch function for the panel circuit, control/relay, or transponder output circuit. (I=on; *=off).
- **Silenceable** A selection that specifies if the device can be silenced during an alarm by pressing the SIGNAL SILENCE key.
- **Walk Test** A selection that specifies if the device will activate during a Walk Test.

How to View Read Status for a Software Zone (Z01-Z99)



From the “Read Status” screen, press **0**, then press the ENTER key. You can now view Read Status for a Software Zone as follows: press **Z**, enter the zone number (01-99), then press the ENTER key. For example, to read the status of Software Zone 07: press **Z**, enter **07**, then press the ENTER key. The control panel now displays information for a Software Zone as shown below.

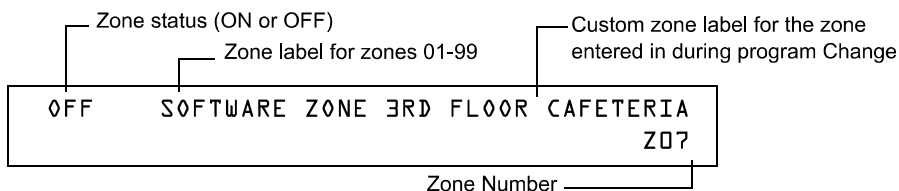
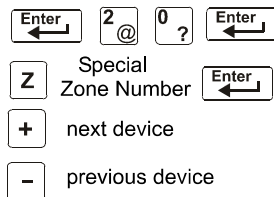

Figure 24 Sample Software Zone Read Status Display

How to View Read Status for a Special Zone (F0-F9)



From the “Read Status” screen, press **0**, then press the ENTER key. You can now view Read Status for a Special Zone as follows: press **Z**, enter the zone number (F0-F9), then press the ENTER key. For example, to read the status of Special Zone F8: press **Z**, enter **F8**, then press the ENTER key. The control panel now displays information for a Special Zone as shown below.

Note: The zone label depends on the type of Special Zone. For example, CODING FUNCTION CODE TYPE for F8.

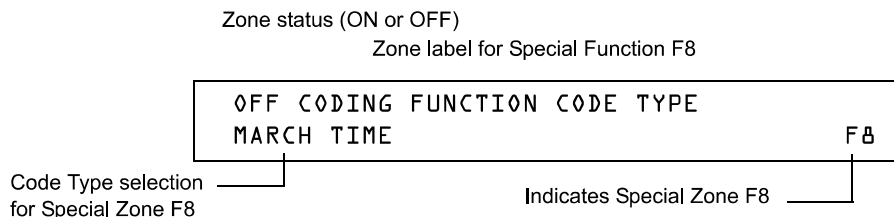
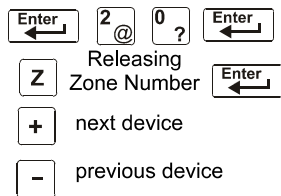

Figure 25 Sample Special Zone Read Status Display

How to View Read Status for a Releasing Zone (R0-R9)



From the “Read Status” screen, press **0**, then press the ENTER key. You can now view the Read Status of a Releasing Zone as follows: press **Z**, enter the zone number (R0-R9), then press the ENTER key. For example, to read the status of Releasing Zone R0, enter **Z**, enter **R0**, then press the ENTER key. The control panel now displays information for a Releasing Zone as shown below.

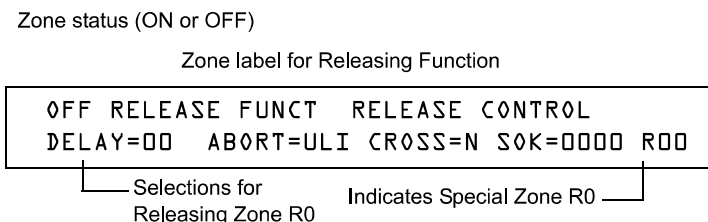
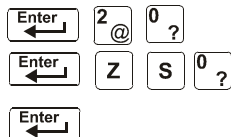

Figure 26 Sample Releasing Zone Read Status Display

How to Read Status for System Functions



The “System Functions” screen specifies global settings for the control panel. From the “Read Status” screen, press **0**, then press the ENTER key. You can now view Read Status for System Functions as follows: press **Z**, enter **S0**, press the ENTER key. Shown below is a sample display and description of items for the Read Status of System Functions:

```
SIL INH=000 AUTO=000 VERIFY=30 USA TIME
TERM=N AC_DLY=Y LocT BLINK=01 ST=4 ACS=N
```

Parameter	Description	Settings
SIL INH=000	Silence Inhibit timer in seconds. Required in Canada and some areas of the USA.	000 = no timer; or the timer duration in seconds up to 300.
AUTO=000	Auto Silence Timer in seconds.	000 = no timer; 600-900 seconds.
VERIFY=30	Alarm Verification Timer	00 = no timer; 00-30 seconds.
USA TIME	Time and date display format	USA TIME or EUR TIME
TERM=N	Terminal supervision	YES – To supervise the wiring of a terminal mode LCD-80. NO – No Terminal mode LCD-80 supervision.
AC_DLY=N	Delays AC loss reporting	YES - AC loss reporting is delayed for approximately 8 hours. NO - No AC loss delay.
LocT	One of three operating modes of a PC or terminal connected to the control panel (through TB15 PC Terminal)	LocT – terminal connected to control panel and located in the same room as the control panel. LocM – terminal connected to control panel but requires password for operation. RemT – terminal connected through a modem for Read Status operations only.
BLINK=01	The rate at which intelligent control or monitor modules blink during polling	BLINK=00: No blink BLINK=01: Devices blink on every poll. BLINK=16: Devices blink every 16th poll.
ST=4	NFPA wiring style operation for the SLC	4 – Style 4 SLC or 6 – both Style 6 and Style 7 SLC
ACS=N	Use ACS Selection Groups	N – No annunciator selected or Y – Select and display ACS Selection Groups

Table 11 System Function Parameters

How to Read Status for Annunciator Selections

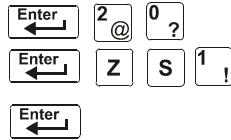

Annunciator Selection screens specify the information that displays on ACS annunciators. From the “Read Status” screen, press 0, then press the ENTER key. You can now view Read Status for System Functions as follows: press Z, enter S, enter annunciation selection number (1-4), press the ENTER key. Sample LCD displays for the Read Status of Annunciator Selection are shown below:

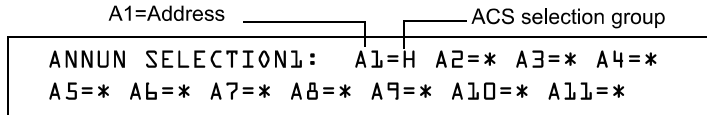

Figure 27 Annunciator Selection 1 Screen

To view the next three annunciator selection screens, press the **+** (NEXT SELECTION) key.

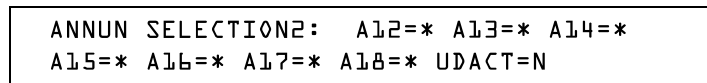

Figure 28 Annunciator Selection 2 Screen

If UDACT=N, the control panel displays the Annunciator Selections 3 and 4 screen, addresses A20-A32, as shown below:

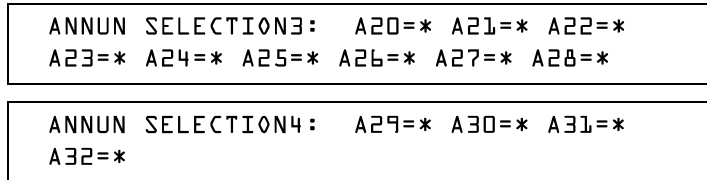

Figure 29 Annunciator Selections 3 and 4 Screens

An Annunciator Selection screen shows the information that will display on the ACS annunciators. The table below contains the ACS display selections.

1 thru 9	Programmable Annunciator #1 thru #9
0	Programmable Annunciator #10
A	8 Systems points + Zones 1-56
B	Zones 57-99, 9 F zones, 8 R zones, 4NAC
C	Loop 1, Modules 1-64
D	Loop 2, Modules 1-64
E	Loop 1, Modules 65-128
F	Loop 2, Modules 65-128
G	Loop 1, Modules 129-159 & Loop 2, Modules 129-159
H	Loop 1, Detectors 1-64
I	Loop 2, Detectors 1-64
J	Loop 1, Detectors 65-128
K	Loop 2, Detectors 65-128
L	Loop 1, Detectors 129-159 & Loop 2, Detectors 129-159
M	Panel circuits 1-1 to 8-8 (64)

Annunciator addresses 1 to 19 can be programmed to any one of the above selections. If there is a UDACT, selections A-M will be sent to Annunciator addresses 20 to 32 respectively.

Table 12 ACS Selection Groups

Continued on the next page...

An example of ACS selections in Annunciator Selection Screen 1:

```
ANNUN SELECTION1:  A1=H A2=C AC=M A4=*
A5=* A6=* A7=* A8=* A9=* A10=* A11=*
```

Figure 30 Annunciator Selection Screen 1 Example

Note: An ACS selection marked with an asterisk (*) indicates no annunciator selection.

The figure above shows annunciator selections for addresses A1-A3 (addresses A4-A10, marked with asterisks, are not selected).

- Annunciators set to annunciator address 1 (A1) display the status of detectors 1-64 on SLC 1 (ACS Selection Group H)
- Annunciators set to annunciator address 2 (A2) display the status of intelligent modules 1-64 on SLC-1 (ACS Selection Group C)
- Annunciators set to annunciator address 3 (A3) display the status of the panel circuits (ACS Selection Group M)

How to Read Status for Battery Levels

Pressing the BATTERY LEVEL  key on the NFS-640 keyboard displays information concerning the state of the battery.

A sample LCD display is shown below:

```
Battery Voltage 27.8V Charging at 0.1A
Status: Normal-Maintenance Charge Rate
```

Figure 31 Battery Level Status

How to View Read Status for Event and Alarm History

Overview

The control panel maintains a History buffer of the last 800 events, each with a time and date stamp. History events include the following:

- All alarms, troubles and operator actions, such as: Acknowledge, System Reset, Signal Silence, Drill, and Walk Test.
- Programming entries (Program Change and Status Change, but not Read Status), along with a number (0-9) indicating the programming submenu (for example, 0=Clear). For an example, see Figure 34.

You can view events from the History buffer in two forms: by displaying all events (option 2, HIST=2) or by displaying alarm events only (option 4, ALARM HIST=4).

Note: The History buffer contains 800 events total, including the alarm events that display for Alarm history. The control panel generates Alarm history from the alarm events that exist in the 800-event History buffer.

How to View Read Status for Event History

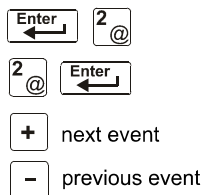

Option 2 (HIST=2) lets you view the total number of events in the History buffer (up to 800 events), then view each event in chronological sequence. From the “Read Status” screen, press 2, then press the ENTER key to display the “Event History” screen. A sample of the Event History screen is shown below:

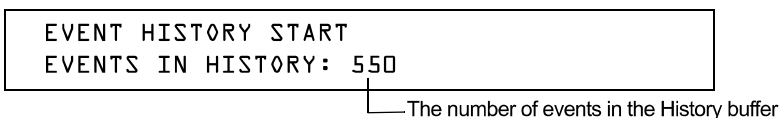

Figure 32 Sample Event History Display

To display events in the History buffer, do the following:

- Press the NEXT SELECTION key to step through each event from the first entry (oldest event first) in the History buffer, or
- Press the PREVIOUS SELECTION key to step through each event from the most recent entry in the History buffer.

Note: The NEXT SELECTION key will show the most recent event first, and then move to its normal function of displaying the oldest events first.

A sample LCD display for a trouble event:

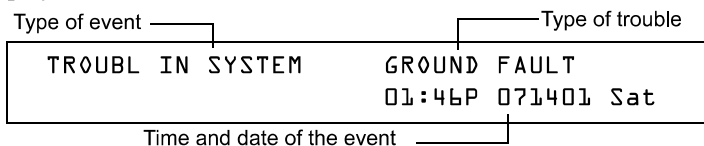

Figure 33 Sample Trouble Event Display

A sample LCD display for a Program Change event:

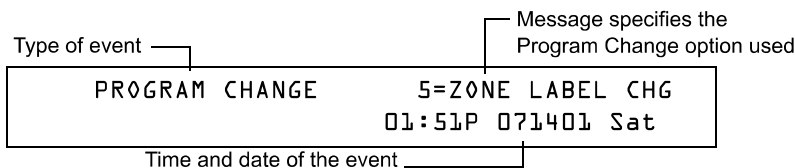
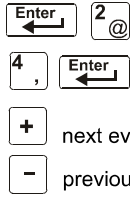

Figure 34 Sample Program Change Event Display

How to View Read Status for Alarm History



Option 4 (ALARM HIST=4) lets you view the total number of alarms in the History buffer (up to 200), then view each alarm in chronological sequence. From the “Read Status” screen, press 4, then press the ENTER key to display the “Event History” screen. A sample Alarm History screen is shown below:

```
ALARM HISTORY START (ESCAPE TO ABORT)
ALARMS IN HIST: 073
```

_____ The number of alarms in the History buffer

Figure 35 Sample Alarm History Display

To display alarms in the buffer, do the following:

- Press the NEXT SELECTION key to step through each alarm from the first entry (oldest alarm first) in the buffer, or
- Press the PREVIOUS SELECTION key to step through each alarm from the most recent entry in the buffer

Note: The NEXT SELECTION key will show the most recent event first, and then move to its normal function of displaying the oldest events first.

A sample display for an alarm event:

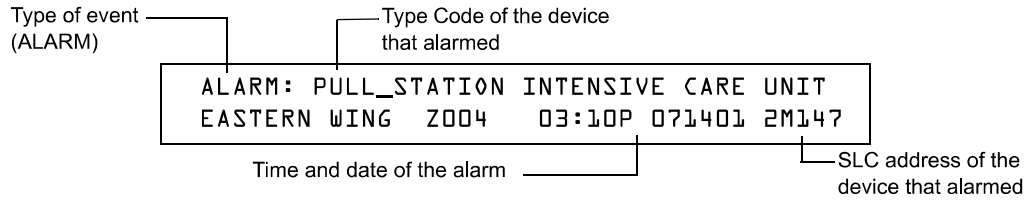

Figure 36 Sample Alarm Event Display

Figure 37

How to Print Points, Event and Alarm History

Overview

Read Point options 1, 3, and 5 in the “Read Status” screen let you print points, event history, and alarm history. This section contains instructions for printing, as well as sample point, event history, and alarm history printouts.

Note: Before printing, make sure your control panel is connected to a compatible printer and the printer is configured according to the manufacturer’s specifications, and that the correct baud rate is selected at the panel.

How to Print Points

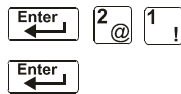

Option 1 (PRNT POINT=1) lets you print a list of all points programmed into the system. From the “Read Status” screen, press **1**, then press the ENTER key to print a list of installed points. A sample Print Point screen is shown below:

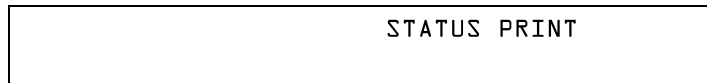
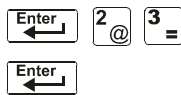

Figure 38 Sample Print Point Display

A sample printout of three points using the Print Point option:

```
NORMAL SMOKE (PHOTO) DETECTOR ADDR 1D043          Z003 000%A8 8 ** 1D043
NORMAL SMOKE (PHOTO) DETECTOR ADDR 1D044          Z003 000%A8 8 ** 1D044
NORMAL SMOKE (PHOTO) DETECTOR ADDR 1D045          Z003 000%A8 8 ** 1D045
```

How to Print Event History



Option 3 (HIST=3) lets you print a list of all events in the History buffer (up to 800). From the “Read Status” screen, press **3**, then press the ENTER key to print a list of events. A sample History Print screen is shown below:

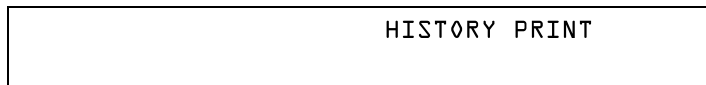
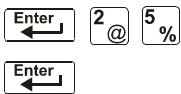

Figure 39 Sample History Print Screen

A sample printout of three events in history using the History Print option:

```
***** EVENT HISTORY START*****
SYSTEM RESET                               02:28P 012201 Mon
ALARM: SMOKE (ION) DETECTOR ADDR 1D075     Z002 02:28P 012201 1D075
ALARM: SMOKE (ION) DETECTOR ADDR 1D076     Z002 02:28P 012201 1D076
ACKNOWLEDGE                                02:28P 012201 Mon
```

How to Print Alarm History



Option 5 (ALARM HIST=5) lets you print a list of alarm events in the History buffer (up to 200). From the “Read Status” screen, press **5**, then press the ENTER key to print a list of alarm events. A sample Print Alarm History screen is shown below:

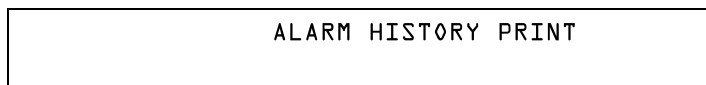

Figure 40 Sample Print Alarm History Display

A sample printout of two alarm events in the History buffer using the Print Alarm History option.

```
*****ALARM HISTORY START*****
ALARM: SMOKE (ION) DETECTOR ADDR 1D075     Z002 02:28P 012201 1D075
ALARM: SMOKE (ION) DETECTOR ADDR 1D076     Z002 02:28P 012201 1D076
*****
PRINT END
```

How to View and Print Hidden Event and Alarm History

The control panel maintains a copy of the preceding History buffer. For instance, if someone clears the History buffer using Status Change programming option 4, the control panel retains a copy of the History buffer. The copy of the preceding History buffer is called a Hidden History buffer and a copy of the preceding Alarm History is called a Hidden Alarm History buffer.

If you attempt to view or print history and the control panel displays one of the screens shown below you can use the options listed in the table below to view the contents of a Hidden History buffer.



Figure 41 History Empty Display

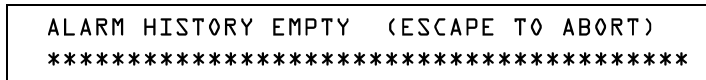

Figure 42 Alarm History Empty Display

Options for viewing and printing Hidden History and Hidden Alarm History do not appear in the LCD display when in Read Status. You can view and print the contents of these Hidden History buffers using the options listed in the table below. You read and print Hidden History and Hidden Alarm History the same way you read and print history using the options that appear on the “Read Status” screen. The table also contains references to the sections that contain instructions for reading and printing history.

To	Press	Refer to
Read Hidden Alarm History	2 @ 6 :	"How to View Read Status for Alarm History" on page 50
Print Hidden Alarm History	2 @ 7 \	"How to Print Alarm History" on page 51
Read Hidden History	2 @ 8 .	"How to View Read Status for Event History" on page 49
Print Hidden History	2 @ 9	"How to Print Event History" on page 51

Table 13 Hidden History Selections

Appendix A: Special Zone Operation

Overview

This section contains information for operating the control panel as detailed in the topics listed below:

Section	Special Zone	Refer to Page
Releasing Zones (R0-R9)	R0-R9	54
Time, Date, and Holiday Functions	F5, F6, F7	57
NAC and Panel Circuit Coding	F8	59
Presignal and Positive Alarm Sequence (PAS) Operation	F0	60

Releasing Zones (R0-R9)

Purpose of Releasing Zones

WARNING

When used for CO₂ releasing applications, observe proper precautions as stated in NFPA 12. Do not enter the protected space unless physical lockout and other safety procedures are fully completed.

Do not use software disable functions in the panel as lockout.

The control panel provides ten Releasing Zones (R0-R9). These are special zones that you can use for up to ten independent releasing operations. This section contains descriptions of each Releasing Function option and an example of how Releasing Zone options work.

For instructions on programming Releasing Functions, refer to the *NFS-640 Programming Manual*.

Each Releasing Zone includes the following releasing options:

Option	Description
Cross Zone	Cross Zones let you program the control panel to activate a Releasing Zone when two or more detectors are alarmed. Cross Zone selections are: Y Two or more detectors are alarmed that are mapped to one of the ten Releasing Zones (R0-R9) Z Two or more detectors are alarmed that are mapped to two different Software Zones and mapped to one of the ten Releasing Zones (R0-R9). H At least one smoke detector mapped to one of the ten Releasing Zones (R0-R9) is alarmed <i>and</i> at least one heat detector mapped to the same Releasing Zone as the smoke detector is alarmed. N Cross Zones not used
Delay Timer	Select a 0–60 second delay before activating a zone.
Abort	An Abort Switch Type Code used to abort activation of a zone.
Manual Release	Allows immediate zone activation by overriding the abort function, cross-zone function, and delay timer.
Soak Timer	Automatically shuts off the releasing device after a preprogrammed period of time. Select 0001-9999 seconds for a Soak Timer or 0000 seconds for no Soak Timer.

Table 14 Releasing Options

How to View Releasing Zone Selections

You can use the Read Status Entry option to view the current selections for a Releasing Zone. For example, to view selections for Releasing Zone R1, press the keys in sequence:



A sample LCD display of a Releasing Function selected for Releasing Zone R1:

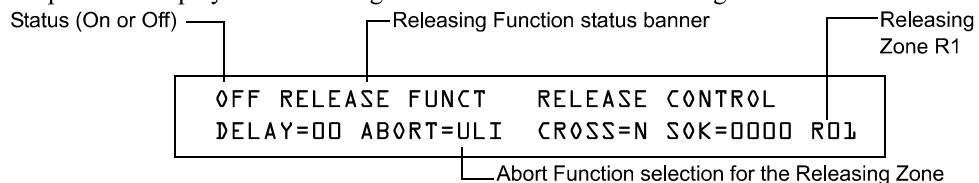

Figure 43 Sample Read Status for a Releasing Zone

How Releasing Zones Operate

The figure below contains an illustrated example of how Releasing Zones work, using cross zone selections with four detectors and an NAC mapped to Releasing Zone 1 (listed as ZR1 in the CBE list). Table 15 lists the cross zone selections and the conditions that activate the Releasing Zone:

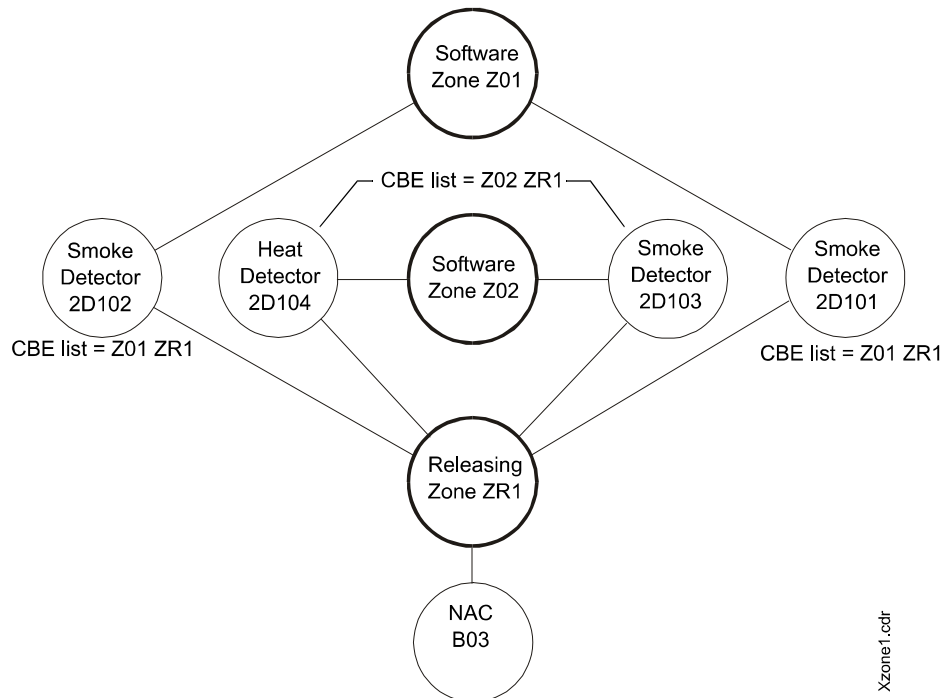
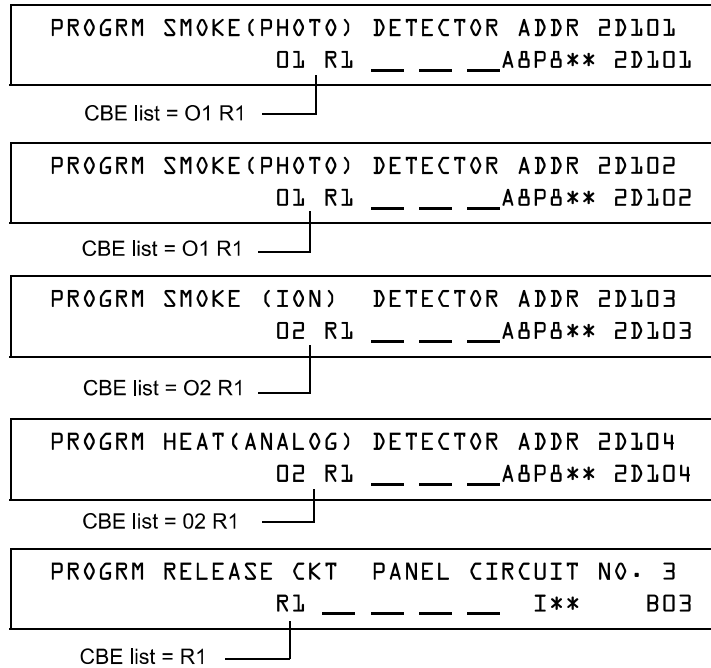

Figure 44 Illustrated Example of Cross Zone Programming

Continued on the next page...

Listing of each Cross Zone option and the conditions required to activate the Releasing Zone, according to the example shown in Figure 44.

Cross Zone Selection (Cross=)	Condition(s) Required to Activate the Releasing zone
Cross= N	An alarm from any detector activates the releasing circuit.
Cross= Y	An alarm from any two detectors activates the releasing circuit.
Cross= Z	<p>An alarm from two detectors mapped to different Software Zones, but mapped to the same Releasing Zone.</p> <ul style="list-style-type: none"> • An alarm from 2D101 and 2D103 – detectors mapped to different zones, but both list ZR1 in their CBE. • An alarm from 2D102 and 2D104 – detectors mapped to different zones, but both list ZR1 in their CBE. • An alarm from 2D101 and 2D104 – detectors mapped to different zones, but both list ZR1 in their CBE. • An alarm from 2D102 and 2D103 – detectors mapped to different zones, but both list ZR1 in their CBE.
Cross= H	Activation of heat detector 2D104 and one smoke detector (2D101, 2D102, or 2D103).

Table 15 Example of Cross Zone Selections

Time, Date, and Holiday Functions

Overview

The control panel includes a real-time clock that displays the time-of-day, the date, and the day-of-week. The clock includes a lithium battery backup. Time displays in a USA format (12-hour time format with month/day/year) or a EUR (European) format as shown below:.

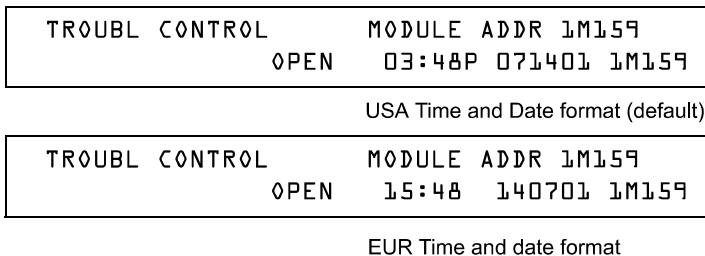

Figure 45 Sample USA and EUR Time/Date Formats

The control panel also provides Time Control zones F5 and F6 for time and date control functions and zone F7 for holiday functions.

How to View Time Control Selections

You can use the Read Status Entry option to view the current selection for the Time function. To do so, press the following keys in sequence:



or



Note: For instructions on programming the Time function, refer to the *NFS-640 Programming Manual*.

The LCD display shows the current selections for the Time Control function. The figure below shows a sample LCD display of a Time Control function:

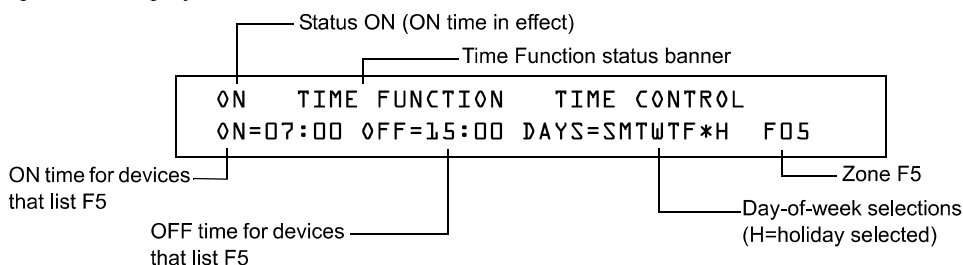

Figure 46 Sample Read Status for Time Function

How to View Holiday Function Selections

You can use the Read Status Entry option to view the current selection for the Holiday function. To do so, press the following keys in sequence:



Note: For instructions on programming the Holiday function, refer to the *NFS-640 Programming Manual*.

The LCD display in Figure 47 gives an example of an LCD display of a Holiday function:

Status ON (holiday function not in effect)
 Holiday Function status banner

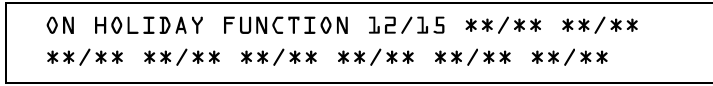

Holiday selections (for zone F7)

Figure 47 Sample Read Status for Holiday Function

How Time Control and Holiday Functions Work

Time and Holiday activation occurs automatically and does not require operator intervention. All outputs with a CBE list containing F5 or F6 activate within the times specified for the days of the week listed in F5 or F6. All smoke detectors with a CBE list containing F5 or F6 switch to their lowest sensitivity (AL:9) within the times specified for the days of the week listed in ZF5 or ZF6. Refer to “Appendix C: AWACS Applications” in the *NFS-640 Programming Manual* for details on setting detector sensitivity.

Time Control is active for all days of the week listed in F5 or F6. Holidays listed in F7 are excluded unless you list Holidays (H) in the day-of-week selection of F5 and F6 (shown in Figure 46). Enter the time functions in a 24-hour format with the OFF time later than the ON time. After changing programming using Time Control, always reset the control panel.

Note: You can turn a NON FIRE control point on and off, by listing zone F5 or F6 in the CBE list of a control/relay module.

You can use Time Control zones F5 and F6 to program non-fire applications such as turning lights on and off, setting a thermostat, and so on. For example, you can program zones F5 and F6 to activate outputs at one time of day and deactivate outputs at later time, on specified days of a week. Table 16 contains descriptions of additional Time Control applications:

Application	Requirement
Control day and night sensitivity of intelligent, addressable detectors	List zone F5 or F6 in the detector CBE. This automatically sets the detector sensitivity to the minimum setting (AL:9) during the day and automatically returns detector sensitivity to programmed sensitivity during the evening.
Control a specific date of-year	Input up to nine date in the Holiday selection screen for Special Zone F7, then list zone F7 (Holiday) in the CBE of a device.

Table 16 Time Control Applications

NAC and Panel Circuit Coding

Overview of Coding

A Coding selection is the Code Type that pulses when the control panel activates an NAC or Panel Circuit mapped to Special Zone F8. Special Zone F8 provides seven coding selections (see Table 17) that you can list in the CBE of an NAC or a Panel Circuit (ICM-4 or CRM-4). To use a Code Type, program an NAC or Panel Circuit to list Zone F8 (reserved for a Code Type) in the NAC or Panel Circuit CBE list.

Note: Control modules (FCM-1, FRM-1, XP5-C) can not be coded.

The table below contains descriptions of the signals that correspond to each NAC Code Type

Coding Selection	Signal	Notes
March Time (default)	120 PPM (pulses Per minute)	Default selection for NACs and Panel Circuits mapped to F8.
Two-Stage	Alert signal (20 PPM) or General Alarm signal (Temporal pattern)	<ul style="list-style-type: none"> Alert signal – When an alarm occurs and not activated by another zone, the output pulses at 20 PPM. General Alarm signal – If not acknowledged within 5 minutes, the control panel switches from 20 PPM to Temporal pattern. ICM-4/ICE-4 modules do not support Two-Stage.
California	10 sec. On, 5 sec. Off, repeats	ICM-4 modules – to enable California code, cut D35 on ICM-4 modules. If D35 is not cut, California code does not pulse and ICM-4/ICE-4 modules pulse steady.
Temporal	0.5 on, 0.5 off, 0.5 on, 0.5 off, 0.5 on, 1.5 off, repeats	Used as a standard general EVAC signal.
Canadian Dual Stage (3 minutes)	Alert signal (20 PPM) Drill Switch activation switches to Temporal pattern	Same as Two-Stage except will only switch to second stage by activation of Drill Switch three minute timer.
Canadian Dual Stage (5 minutes)	Alert signal (20 PPM) Drill Switch activation switches to Temporal pattern	Same as Two-Stage except will only switch to second stage by activation of Drill Switch five minute timer.
System Sensor Strobe		Synchronizes System Sensor ADA horn/strobes.

Table 17 F8 Code Types and Audio Signals

How to View Coding (F8) Selections

You can use the Read Status Entry option to view the current selection for the Coding function. To do so, press the following keys in sequence:



Note: For instructions on programming the Coding function, refer to the *NFS-640 Programming Manual*.

The LCD display shows the current selections for the Code Type. Figure 48 shows a sample LCD display of a Code Type selection of March Time:

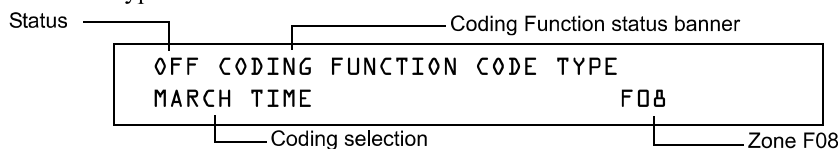

Figure 48 Sample Read Status for Coding Function

How to Respond to an Alarm with Coding

If an alarm occurs with a Coding selection, the control panel latches the control panel in alarm and pulses outputs mapped to F8 at the pulse specified by the Coding selection (see Table 17). To silence the outputs, press the SIGNAL SILENCE key.

Presignal and Positive Alarm Sequence (PAS) Operation

Overview

This section describes the Presignal and PAS selection, and provides instructions on how to do the following:

- View Presignal and PAS selections,
- Respond to an alarm with Presignal
- Operate the control panel with a Presignal Delay Timer only
- Operate the control panel with a Presignal Delay Timer and PAS

What is Presignal and PAS?

Presignal is a feature that initially causes alarm signals to only sound in specific areas, monitored by qualified persons. This allows delay of the alarm from 60 to 180 seconds after the start of alarm processing. The control panel Presignal feature provides two selections:

Note: Presignal differs from the Alarm Verification Timer which does not require human intervention.

- A Presignal Delay Timer (60-180 seconds) that delays activation of all outputs with a CBE that includes Special Zone F0.
- A PAS selection, in addition to the Presignal Delay Timer, that allows a 15-second time period for acknowledging an alarm signal from a fire detection/initiating device. If the alarm is not acknowledged within 15 seconds, all local and remote outputs activate immediately and automatically.

An illustration of Presignal and PAS timing.

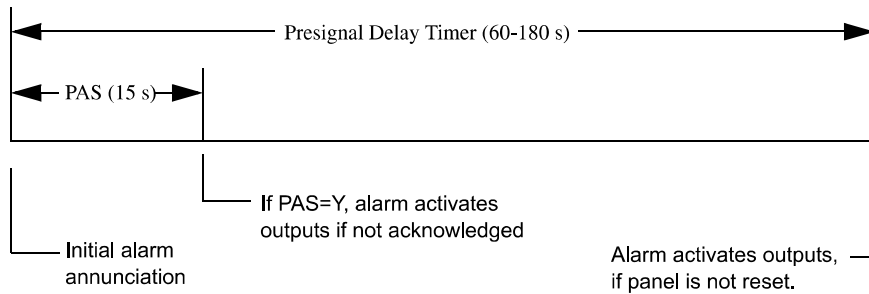

Figure 49 Presignal and PAS Time

How to View Presignal and PAS Selections

You can use the Read Status Entry option to view the current selection for the Presignal function. To do so, press the keys in sequence:



Note: For instructions on programming the Presignal function, refer to the *NFS-640 Programming Manual*.

The LCD display shows the current selections for the Presignal function. The figure below shows a sample LCD display of a Presignal function selected for PAS and a Presignal Delay Timer of 60 seconds:

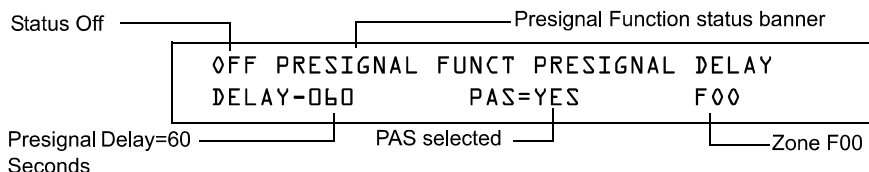

Figure 50 Sample Read Status for Presignal Function

Note: If any monitor modules are programmed with a PAS INHIBIT Type Code and a fire alarm occurs, zone F0 goes false and aborts the Presignal Delay Timer.

How to Respond to an Alarm with a Presignal Delay Timer (no PAS)

If an alarm occurs with a Presignal Delay Timer (60-180 seconds), the control panel displays the type of device and the SLC address of the device causing the alarm. If a second alarm occurs during the Presignal Delay Timer, the control panel aborts the Presignal Delay Timer and activates all programmed outputs. A sample Alarm screen for a monitor module is shown below:

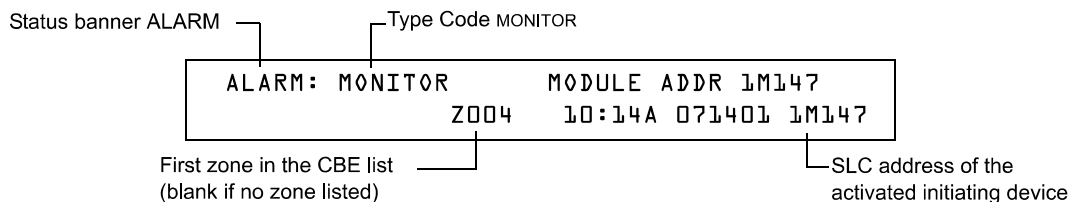

Figure 51 Sample Alarm Display Screen

The FIRE ALARM LED flashes and the panel sounder pulses a steady tone. The control panel latches until the alarm is corrected and you press the SYSTEM RESET key to reset the control panel. You have the duration of the Presignal Delay Timer (60-180 seconds) to respond to the alarm before the control panel automatically activates all outputs programmed to F0. You can take the following actions:

- To silence the panel sounder and change the FIRE ALARM LED from flashing to steady, press the ACKNOWLEDGE/SCROLL DISPLAY key.
- To abort the Presignal Delay Timer, turn off the panel sounder and all silenceable output circuits and light the SIGNALS SILENCED LED by pressing the SIGNAL SILENCE key.
- To manually activate all outputs programmed to F0, press the DRILL key. The Manual Evacuate screen appears, the panel sounder pulses and the FIRE ALARM LED changes from flashing to steady. The Manual Evacuate screen and Alarm screen display alternately at 3-second intervals.

Continued on the next page...

If the Presignal Delay Timer reaches its programmed value, without operator intervention, the control panel activates all outputs programmed to F0.

How to Respond to an Alarm with a Presignal Delay Timer (PAS selected)

If an alarm occurs with a Presignal Delay Timer (60-180 seconds) and PAS selected, the control panel displays an Alarm screen that shows the type of device and the SLC address of the device causing the alarm. When an alarm comes from an initiating device with a CBE list that includes F0 (with PAS selected), the control panel delays the following outputs:

- System Alarm relay
- TM-4 Polarity Reversal Alarm output
- TM-4 Municipal Box output

Note: These outputs do not delay for Presignal operations without PAS selected.

If a second alarm occurs during the Presignal Delay Timer, the control panel aborts the Presignal Delay Timer and activates all programmed outputs.

A sample Alarm screen for a monitor module:

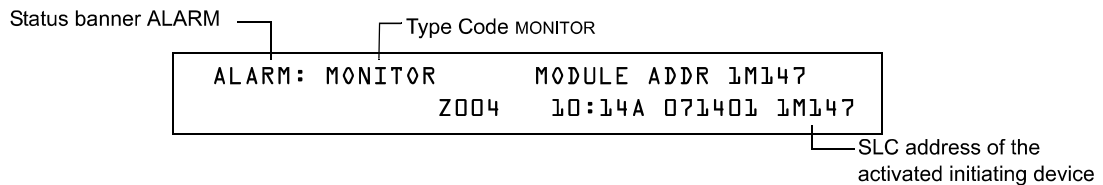

Figure 52 Sample Alarm Display Screen

The FIRE ALARM LED flashes and the panel sounder pulses a steady tone. The control panel latches until the alarm is corrected and you press the SYSTEM RESET key to reset the control panel. You have 15 seconds to acknowledge the alarm or the control panel automatically activates all outputs programmed to F0. If you acknowledge the alarm within 15 seconds, the control panel increases the delay time to the full Presignal Delay Timer (60-180 seconds). You have the duration of the Presignal Delay Timer to respond to the alarm before the control panel activates all outputs programmed to F0. You can take the following actions:

- To increase the delay to the full programmed Presignal Delay Timer, press the ACKNOWLEDGE/SCROLL DISPLAY key. The panel sounder goes silent and the FIRE ALARM LED changes from flashing to steady.
- To abort the Presignal Delay Timer, turn off the panel sounder and all silenceable output circuits and light the SIGNALS SILENCED LED, press the SIGNAL SILENCE key.
- To manually activate all outputs programmed to F0, press the DRILL key. The Manual Evacuate screen appears, the panel sounder pulses and the FIRE ALARM LED changes from flashing to steady. The Manual Evacuate screen and Alarm screen display alternately at 3-second intervals.

If the Presignal Delay Timer reaches its programmed value, without operator intervention, the control panel activates all outputs programmed to F0.

Appendix B: Intelligent Detector Functions

Note: For instructions on selecting Intelligent Detector Functions, refer to the *NFS-640 Programming Manual*.

Descriptions for Intelligent Detector Functions

Function	Description
Analog Display	The control panel reads and displays analog information from the 318 analog detectors (159 per SLC). The display shows the sensed air at the detector as a percentage of the alarm threshold for each detector.
Sensitivity Adjust	Nine selections for manually setting intelligent detector alarm levels within the UL range. <i>If using Ionization detectors in duct applications, set Sensitivity Adjust to Level 1.</i> Note: Refer to the <i>NFS-640 Programming Manual</i> for detector sensitivity information.
Day/Night Sensitivity Operation	You can program the system to automatically force smoke detectors to minimum sensitivity during the day. Refer to "Time, Date, and Holiday Functions" on page 57.
Maintenance Alert	When compensation reaches the limit of the amount of drift compensation that can be safely applied, the control panel reports a special trouble condition, according to National Fire Alarm Code standards. This condition also activates if the detector remains at very high or very low measured air levels for an extended time.
Automatic Test Operation	The control panel performs an automatic test of each detector every 256 minutes. Failure to meet the test limits causes an Auto Test Fail trouble.
Type Code Supervision	The control panel monitors hardware device Type Codes for each installed device at regular intervals (an interval can take up to 40 minutes for a full capacity system). If a mismatch of type compared to the program occurs, the control panel generates a point trouble labelled Invalid Type.
LED Control Operation	A global program selection to prevent detector LEDs from blinking as a result of polling during normal operation. A typical application is a sleeping area where a blinking light can distract people. As a standard function, independent of this programming selection, the control panel allows all LEDs to turn on in alarm.
Alarm Verification Timer and Verification Counter Operation	The control panel performs alarm verification on programmed intelligent smoke detectors. The Alarm Verification Timer is a global program selection of 0–60 seconds (ULC installations can not exceed 30 seconds). Each detector includes a Verification Counter, which displays the number of times that a detector entered verification but did not time-out to alarm. The Verification Counter increments to 99 and holds.

Table 18 Intelligent Detector Functions

Notes

Appendix C: Remote Terminal Access

General Description

The control panel can communicate with a remote terminal or computer connected to the EIA-232 PC terminal port. Refer to the *NFS-640 Installation Manual* for installation information.

Note: See the *NFS-640 Programming Manual* for instructions on enabling the CRT.

This port may be set up for interactive operation or for monitoring only. Interactive operation requires that all equipment be UL-listed under UL Standard for Safety UL 864 and be installed and set up as directed under Local Terminal Mode (LocT) or Local Monitor Mode (LocM).

ITE (Information Technology Equipment) listed equipment is allowed for ancillary system monitoring when the system is installed and set up as directed under Remote Terminal Mode (RemT). You can also use Outlasted equipment for system servicing or programming.

Operating Modes

The control panel provides three operating modes for the CPU EIA-232 PC/Terminal port:

- Local Terminal - LocT
- Local Monitor - LocM
- Remote Monitor - RemM

You select the operating mode during control panel programming (Global System Functions). For more information, refer to the *NFS-640 Programming Manual*.

The following subsections outline the functions, password requirements, and additional information for each operating mode.

Local Terminal Mode (LocT)

Functions, passwords, and special requirements of Local Terminal Mode (LocT) are:

- Functions:** Read Status, Alter Status, and Control Functions (Table 19).
- Passwords:** User-defined password for Alter Status functions.
- Requirements:** The terminal must be mounted in a UL 864 listed enclosure or positioned to provide equivalent protection against unauthorized use.

Functions available with the Local Terminal Mode:

Function	Lets you...
Read Status	<ul style="list-style-type: none"> • Display the status of an individual point (Detector, Module, Panel Circuit, or Zone). • Display a list of all the points in Alarm or trouble. • Display a list of all programmed points in the system. • Step through the History buffer event by event. • Display the entire History buffer.
Alter Status	<ul style="list-style-type: none"> • Disable/Enable an individual point. • Change the sensitivity of a detector. • Clear the verification counter of all detectors. • Clear the entire History buffer. • Set the AWACS alert and action levels.
Control Functions	<ul style="list-style-type: none"> • Acknowledge. • Signal Silence. • System Reset. • Drill.

Table 19 Local Terminal Mode Functions

Local Monitor Mode (LocM)

Functions, passwords, and special requirements of Local Monitor Mode (LocM) are:

- Functions:** Read Status, Alter Status, and Control Functions (Table 20).
- Passwords:** User-defined password for Alter Status and Control functions.
- Requirements:** Password security feature for Control Functions eliminates the need for mounting the CRT-2 in an enclosure.

Functions available with the Local Monitor Mode:

Function	Lets you...
Read Status	<ul style="list-style-type: none"> • Display the status of an individual point (Detector, Module, Panel Circuit, or Zone). • Display a list of all the points in Alarm or trouble. • Display a list of all programmed points in the system. • Step through the History buffer event by event. • Display the entire History buffer.
Alter Status	<ul style="list-style-type: none"> • Disable/Enable an individual point. • Change the sensitivity of a detector. • Clear the verification counter of all detectors. • Clear the entire History buffer. • Set the AWACS alert and action levels.
Control Functions	<ul style="list-style-type: none"> • Acknowledge • Signal Silence • System Reset • Drill

Table 20 Local Monitor Mode Functions

Remote Terminal Mode (RemT)

Functions, passwords, and special requirements of Remote Terminal Mode (RemT) are:

- Functions:** Read Status only. See Table 21.
- Passwords:** None
- Requirements:** Use with UL ITE-listed terminals, including personal computers with the VeriFire™ Tools or terminal emulation software. Intended for terminals connected through modems, including FSK modems connected through a public switched telephone network.

Functions available with the Remote Terminal Mode:

Functions	Lets you...
Read Status	<ul style="list-style-type: none"> • Display the status of an individual point (Detector, Module, Panel Circuit, or Zone). • Display a list of all the points in Alarm or trouble. • Display a list of all programmed points in the system. • Step through the History buffer event by event. • Display the entire History buffer.
Alter Status	N/A
Control Functions	N/A

Table 21 Remote Terminal Mode Functions

Using the CRT-2 for Read Status

Overview

This section shows how to perform Read Status functions from a CRT-2.

Note: See the *NFS-640 Programming Manual* for instructions on enabling the CRT port.

For more information see the “Read Status” section of this manual.

Function	Lets you...
Read Point	Read the status of any point in the system (detectors, modules, panel circuits, software zones, and system parameters).
Alm/Tbl Status	Display a list of all devices in the system that are in Alarm or trouble.
Read All Points	Display a list of all points programmed in the system. This list will display the status of all addressable detectors, modules, panel circuits, system parameters and software zones.
History Step	Step through the History buffer one event at a time.
History-All	Send the entire History buffer to the CRT, from the most recent event to the oldest event.

Table 22 Read Status Functions

Accessing Read Status Options

Access the Read Status function from the CRT-2 by following these steps.



1. Turn on the CRT-2, which is connected to the control panel.
2. Press the Read Status function key. The control panel displays the “Read Status” menu options:

```
Rd Point=1, Rd Alm/Tbl=2, All Points=3, Hist:Step=4/All=5, Ala-Hist:Step=6/All=7
```

From the Read Status menu, you can select options 1-7.

Read Point

From the “Read Status” menu, select option **1** - Read Point. The CRT-2 displays the following:

Press  

Type (n)D(nnn), (n)M(nnn), P(nn), Z(nn), F(n),, R(n) or S(n) then hit Enter

Address (01-159) Number

SLC Number

Enter the following:

1. Enter SLC loop number “1” or “2”.





Note: Press **F5** to scroll forward through a list of devices. Press **F6** to scroll back through a list of devices.

2. Enter the first letter of the device, using upper case letters.
 - Detector = “D”
 - Module = “M”
 - Panel circuit = “P”
 - Zone = “Z”
 - Special Function = “F”
 - Releasing Zone = “R”
 - System Parameter = “S”

3. Enter the address or number of the device.

4. Press <Enter>.

Example Read points for detectors 1D001 and 1D002 on SLC 1:

Press  D    

```
NORMAL SMOKE(PHOTO) DETECTOR ADDR 1D001 Z03 Z Z Z Z 000%A5 PA:3 ** 1D001
```

Press 

```
NORMAL SMOKE(PHOTO) DETECTOR ADDR 1D002 Z03 Z Z Z Z 000%A5 PA:3 ** 1D002
```

Display Devices in Alarm or Trouble

From the “Read Status” menu, select option **2** - Read All Points:

Press  

```
TROUBL SMOKE(PHOTO) DETECTOR ADDR 1D001 Z03 INVALID REPLY 01;09P 011399 1D001
TROUBL SMOKE(ION) DETECTOR ADDR 1D002 Z02 INVALID REPLY 01;09P 011399 1D002
TROUBL SMOKE MONITOR MODULE ADDR 1M002 Z04 INVALID REPLY 01;09P 011399 1M001
```

Display the Status of all Programmed Points

From the “Read Status” menu, select option **3** - Read All Points. The CRT-2 displays a list of the status of all addressable detectors, modules, panel circuits, system parameters and software zones:

Press

```
NORMAL SMOKE(PHOTO) DETECTOR ADDR 1D001 Z03 Z Z Z Z 000%A5 PA:0 ** L1D001
NORMAL SMOKE(ION) DETECTOR ADDR 1D002 Z02 Z Z Z Z 00%A5 PA:0 ** L1D002
NORMAL HEAT (ANALOG) DETECTOR ADDR 1D003 Z01 Z Z Z Z 000%A5 PA:0 * L1D003
OFF CONTROL MODULE ADDRESS 1M049 Z00 Z Z Z Z IS* L1M049
NORMAL MONITOR MODULE ADDRESS 1M050 Z06 Z Z Z Z L1M050
```

View the History Buffer

From the “Read Status” menu select option **4** - History-Step. This option lets you step through the History buffer one event at a time:

Press

```
EVENT History Start Events in HIST:005
```

The first line that appears displays the number of events in the History buffer. Step through the History buffer one event at a time by pressing the Next **F5** or Prior **F6** function keys.

Send the History Buffer to the CRT-2

From the “Read Status” menu select option **5** - History-All. This option sends the entire History buffer to the CRT-2, from most recent event to oldest event:

Press

```
***** EVENT HISTORY *****
System Normal 04;15P Wed 07/07/01
SYSTEM RESET 04;15P Wed 07/07/01
ALARM SILENCED 04;15P Wed 07/07/01
ACKNOWLEDGE 04;14P Wed 07/07/
01ALARM: PULL STATION MODULE ADDRESS 1D151 Zone 06 04;14P 07/07/01 M151
***** PRINT END *****
```

Semicolon

The semicolon, a control character in networking applications, separates the hour and minute of events displayed from history. If events display as they occur, a colon separates the hour and minute.

View the Alarm History Buffer

From the “Read Status” menu select option **6** -Alarm-History:Step. This option lets you step through the Alarm History buffer one event at a time:

Press

```
***** ALARM HISTORY START *****
ALARM: MAN_RELEASE MODULE ADDR 1M065 10:21A 050501 1M065
ALARM: MAN_RELEASE MODULE ADDR 1M065 10:19A 050501 1M065
ALARM: MAN_RELEASE MODULE ADDR 1M065 03:20P 050401 1M065
ALARM: SMOKE (ION) DETECTOR ADDR 1D129 03:20P 050401 1D129
```

The first line that appears displays the number of events in the History buffer. Step through the Alarm History buffer one event at a time by pressing the Next **F5** or Prior **F6** function keys.

Send the Alarm History Buffer to the CRT-2

From the “Read Status” menu select option 7 - History-All. This option sends the entire History buffer to the CRT-2, from most recent event to oldest event:

Press  

```
***** ALARM HISTORY START *****
ALARM: MAN_RELEASE  MODULE ADDR 1M065          10:21A 050501 1M065
ALARM: MAN_RELEASE  MODULE ADDR 1M065          10:19A 050501 1M065
ALARM: MAN_RELEASE  MODULE ADDR 1M065          03:20P 050401 1M065
ALARM: SMOKE (ION)  DETECTOR ADDR 1D129        03:20P 050401 1D129
```

Using the CRT-2 for Alter Status

Overview

This section shows how to do Alter Status functions from a CRT-2

Note: The panel must be in Local Terminal Mode (LocT) or Local Monitor Mode (LocM).

Note: See the *NFS-640 Programming Manual* for instructions on enabling the CRT port.

Function	Lets you...
Disable	Enable or disable detectors, modules, or panel circuits.
Alarm/Pre-Alarm	Change the Alarm and Pre-Alarm levels of any addressable detector in the system.
Clear Verification	Clear the verification counter for all the addressable detectors in the system.
Clear History	Clear the contents of the History buffer.
Set Action/Alert	Set the Pre-Alarm for Alert or Action.

Table 23 Alter Status Functions

Accessing Alter Status Options





Access the Alter Status function from the CRT-2 by following these steps.

1. Turn on the CRT-2 connected to the control panel.
2. Press the **Alter Status** function key. The control panel displays the Password screen:

Press 

Enter Status Change Password or Escape to Abort

3. Enter the Status Change Password. The factory default Status Change Password is **11111**. The password does not display on the CRT-2. Five asterisks will appear in place of the password:

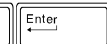
Press      

The Alter Status Options menu appears:

1=Disable 2=Alarm/Prealarm 3=Clear Verification 4=Clear History 5=Alert/Action

From the Alter Status Options menu, you can select options 1-5.

Enable or Disable Detectors, Modules, or Panel Circuits

From the "Alter Status" menu select option **1** - Disable. Disable lets you enable or disable detectors, modules, panel circuits, or zones:

Press

SLC number
Address (01-159)

```

Disable/Enable. Type nD(nnn) / nMnnn / P(nn) / Z(nn) then Enter
STATUS CHANGE          Dis/Ena point          08:29A Wed 07/07/99
Number
    
```

Enter the following:

1. Enter the SLC loop number "1" or "2".
2. Enter the first letter to read one of the following, using upper case letters:
 - Detector = "D"
 - Module = "M"
 - Panel Circuit or NAC = "P"
 - Zone = "Z"
3. Enter the address or number of the device.
4. Press ENTER and a display similar to the following will appear.

Example Disable Detector address 101 on SLC1:

Press

```

D101 Now Enabled, Enter E(Enable) / D(Disable) or Esc. to Abort
    
```

Press **D** to Disable (**E** to Enable); then press ENTER:

Press

```

Device now disabled
TROUBL SMOKE(PHOTO) DETECTOR ADDR 101 Z03 DEVICE DISABLED 08:29A Wed 07/07/99 D101
    
```

Change Alarm and Pre-Alarm levels





This option lets you change the Alarm and Pre-Alarm levels of any addressable detector in the system. To do so, follow these steps.

1. From the "Alter Status" menu select option **2** - Alarm/Pre-Alarm:

Press  

```
Det. Alarm/Prealarm level, type address D(nnn), then Enter
STATUS CHANGE Alarm/Prealarm level 09:53A Wed 07/07/99
```

2. Enter the address of the detector you wish to change. For example, change alarm and Pre-Alarm levels for detector 102 on SLC 1 to Alarm Level 4 & Pre-Alarm Level 2.

Press           

```
STATUS CHANGE Alarm/Prealarm level 09:53A Wed 07/07/99
D102 sens. at level 5, Prealarm at level 3, Enter AxPx to change, Esc. to Abort
D102 now set at new Alarm level 5 and new Pre-alarm level 2
```

Clear the Verification Counter

Clear Verification lets you clear the verification counter for all the addressable detectors in the system:

Press  

```
STATUS CHANGE Clear verify count 09:37A Wed 07/07/99
```

Clear the Entire History Buffer

Clear History lets you clear the entire History buffer:

Press  

```
***** History Clear *****
```

Set the Pre-Alarm for Alert or Action

Set Action/Alert lets you set the Pre-Alarm for Alert or Action. For example, Change Pre-Alarm from “Alert” to “Action” as follows:

Press

```
Set Pre-alarm Alert(NO)/Action(YES). Type N or Y then Enter
STATUS CHANGE      Change Alert/Action                      09:37A Wed 07/07/99
```

Press

```
Pre-alarm now set for ACTION
```

NOTES

NOTES

NOTES

A

Abort 54
 Acknowledge/Scroll Display control key 15
 Active Supervisory Signal 27–28
 panel indication 27
 response to 27
 Type Codes 28
 Alarm Verification Timer 36, 63
 Alarm. See Fire Alarm 21
 Analog Display 63
 Annunciator Selections, read status 47
 Auto Silence Timer 36
 Automatic Test Operation 63

B

Battery Levels, read status 48

C

Caution
 Disabling a zone disables all input and output... 30
 Coding
 to view F8 selections 59
 Coding, NAC and Panel Circuit 59
 Control Keys 15
 Control Panel Keys and Indicators, illustration 13
 Control/Relay Module Trouble
 panel indication 34
 response to 35
 Type Codes 33
 Control/Relay Module, read status 43
 Cooperative Multi-Detector selection, read status 42
 CRM-4RK 33
 Cross Zone 54
 Cross Zone Programming illustration 55
 CRT-2 and Alter Status 73
 Accessing 73
 Alarm and Pre-alarm levels 75
 clear history buffer 75
 Detectors, Modules, Panel Circuits 74
 set Pre-alarm 76
 Verification Counter Clear 75
 CRT-2 and Read Status 69
 Accessing 69
 Display devices in alarm or trouble 70
 Point 70
 status of programmed points 71
 View/send alarm history buffer 71
 View/send history buffer 71
 CRT-2 and Read Status. See Appendix C

D

Date Functions 57
 Day/Night Sensitivity Operation 63
 DCM-4RK 33
 Delay Timer 54

Detector
 fire alarm type codes 22
 Functions 63
 Read Status 42
 supervisory alarm type codes 28
 Disabled Points 30
 Drill control key 15

E

EDP-listed equipment, see also ITE-listed equipment 65

F

Fire Alarm 21–22
 panel indication 21
 response to a 21, 59
 Fire Alarm LED 14
 Fire Control Type Code, active point 31

H

Hidden History, read status and print 52
 History, event and alarm, read status 49
 Holiday Functions 57
 to view selections 58

I

ICM-4RK 33
 Increment Number key 17
 ISO-X module 37
 ITE-listed equipment 65

L

Lamp Test control key 16
 Latching Supervisory Type Code 27
 latching/non-latching type codes. See particular type code for definition.
 LED Control Operation 63
 Local Control setting and control keys 15
 LocM (Local Monitor) 65, 67
 LocT (Local Terminal Mode) 65, 66

M

Maintenance Alert 63
 Manual Release 54
 Monitor Module
 fire alarm type codes 22
 non-alarm type codes 31
 Read Status 43
 security type codes 26
 supervisory alarm type codes 28
 trouble monitor type codes 32

N

NAC Circuit Trouble
 panel indication 34

- response to 35
- Type Codes 33
- NAC Circuit, read status 44
- Non-Alarm Points 31
- Non-Fire Point, active, panel indication 31
- Non-latching Supervisory Type Code 28
- Normal Mode of Operation 20

O

- Output Circuit Trouble 33–35

P

- Panel Circuit Trouble
 - panel indication 34
 - response to 35
 - Type Codes 33
- Panel Circuit, read status 44
- Point Disabled LED 14
- Power LED 14
- Pre-alarm LED 14
- Pre-Alarm Warning 29
 - action level 29
 - alert level 29
 - panel indication 29
 - response to 29
- Presignal and Positive Alarm Sequence (PAS)
 - response to Presignal Delay Timer alarm (no PAS) 61
 - response to Presignal Delay Timer alarm (PAS selected) 62
 - to view selections 61

R

- Read Status 39–52
 - to enter 39
 - to print 51
 - alarm history 51
 - event history 51
 - points 51
 - print hidden event and alarm history 52
 - print points 51
 - to view 40
 - annunciator selections 47
 - battery levels 48
 - detector information 42
 - devices, zones, system settings 41
 - event and alarm history 49
 - point or zone information 41
 - Releasing Zone (R0-R9) 45
 - releasing zone selections
 - software zones 45
 - Special Zone (F0-F9) 45
 - System Functions 46
 - total of installed devices 41
 - using a CRT. See Appendix C
- Recall Last Entry key 17

- Releasing Zone (R0-R9), read status 45
- Releasing Zones (R0-R9) 54–56
- Remote Terminal Access 65–76
- RemT, Remote Terminal Mode 65, 68

S

- Security Alarm 25
 - Not Suitable for Canadian Applications 25
 - panel indication 25
 - response to a 25
- Security LED 14
- Sensitivity Adjust 63
- Shortcuts to Operating Functions 10
- Signal Silence control key 15
- Signals Silenced LED 14
- Silence Inhibit Timer 36, 37
- Soak Timer 54
- Software Zone (Z01-Z99), read status 45
- Special Zone Operation 53–62
- Special Zone, read status 45
- Supervisory LED 14
- Supplemental Documentation 10
- System Functions, read status 46
- System Normal Message 20
- System Reset control key 16
- System Status Indicator LEDs 14
- System Timers 36
 - Alarm Verification Timer 36
 - Auto Silence Timer 36
 - Silence Inhibit Timer 36, 37
 - to view selections 36
- System Trouble 23–24
 - panel indication 23
 - response to 23
- System Trouble LED 14

T

- Time Functions 57
 - to view selections 57
- Timers. See System Timers 36
- Transponder Points 33
- Trouble Monitor 32
 - response to 32
 - trouble monitor type codes 32
- Type Code Supervision 63
- Type Codes
 - Fire Alarm 22
 - Non-alarm 31
 - Security 26
 - Supervisory 28
 - Trouble 32

V

- VCM-4RK 33
- Verification Counter 75

W

Warning

When used for CO2 releasing applications... 19, 54

Waterflow Circuit operation 37

X

XP5-C transponder points 33

XPC transponder points 33

Limited Warranty

The manufacturer warrants its products to be free from defects in materials and workmanship for eighteen (18) months from the date of manufacture, under normal use and service. Products are date stamped at time of manufacture. The sole and exclusive obligation of the manufacturer is to repair or replace, at its option, free of charge for parts and labor, any part which is defective in materials or workmanship under normal use and service. For products not under manufacturing detestably control, the warranty is eighteen (18) months from date of original purchase by the manufacturer distributor unless the installation instructions or catalog sets forth a shorter period, in which case the shorter period shall apply. This warranty is void if the product is altered, repaired or serviced by anyone other than the manufacturer or its authorized distributors or if there is a failure to maintain the products and systems in which they operate in a proper and workable manner. In case of defect, secure a Return Material Authorization form from our customer service department. Return product, transportation prepaid, to the manufacturer.

This writing constitutes the only warranty made by the manufacturer with respect to its products. The manufacturer does not represent that its products will prevent any loss by fire or otherwise, or that its products will in all cases provide the protection for which they are installed or intended. Buyer acknowledges that the manufacturer is not an insurer and assumes no risk for loss or damages or the cost of any inconvenience, transportation, damage, misuse, abuse, accident or similar incident.

THE MANUFACTURER GIVES NO WARRANTY, EXPRESSED OR IMPLIED, OF MERCHANTABILITY, FITNESS FOR ANY PARTICULAR PURPOSE, OR OTHERWISE WHICH EXTEND BEYOND THE DESCRIPTION ON THE FACE HEREOF. UNDER NO CIRCUMSTANCES SHALL THE MANUFACTURER BE LIABLE FOR ANY LOSS OF OR DAMAGE TO PROPERTY, DIRECT, INCIDENTAL OR CONSEQUENTIAL, ARISING OUT OF THE USE OF, OR INABILITY TO USE THE MANUFACTURER'S PRODUCTS. FURTHERMORE, THE MANUFACTURER SHALL NOT BE LIABLE FOR ANY PERSONAL INJURY OR DEATH WHICH MAY ARISE IN THE COURSE OF, OR AS A RESULT OF, PERSONAL, COMMERCIAL OR INDUSTRIAL USE OF ITS PRODUCTS.

This warranty replaces all previous warranties and is the only warranty made by the manufacturer. No increase or alteration, written or verbal, of the obligation of this warranty is authorized.



World Headquarters
12 Clintonville Road
Northford, CT 06472-1653 USA
203-484-7161
fax 203-484-7118

www.notifier.com

NOTIFIER is a **Honeywell** company

ISO 9001
CERTIFIED
ENGINEERING & MANUFACTURING